

DYWIDAG Bonded Post-Tensioning Systems using Strands



DYWIDAG Multistrand Tendons secure one of the largest Interstate Bridges in Hungary

Köröshegy Bridge, M7 Interstate



One of the largest prestressed concrete interstate bridges in Hungary was built as part of the 15 km extension of the M7 interstate between Zamárdi and Balatonszárszó near Köröshegy. Construction of the bridge began in summer of 2004. This route leads from Slovenia to Budapest, passing south of Lake Balaton. Due to its limited construction time of only 21/2 years and the high demands made on the building technology, the bridge was definitely an engineering performance of outstanding importance. Because of the 90 m height of the bridge and the short construction time, the 23.80 m wide deck that will carry

two traffic lanes is being built using the prestressed concrete construction method instead of a combination of steel or composite structure. The bridge superstructure is supported by 16 piers erected on bored piles in the range of 1.2 to 1.5 m in diameter and depths of 22 to 29 m. The height of the piers varies between 1 m at the edge of the valley and 90 m in the middle of the bridge. The piers were built in 5 m sections using a climbing formwork system. The 17 bridge spans (60 m + 95 m + 13 x 120 m + 95 m + 60 m) were built using the cantilever method and post-tensioned with DYWIDAG Multistrand Tendons. Starting from the piers, each span was built to the right and left in one pour each and then the segments were post-tensioned against each other. A special feature here was a pour section of 11.0 m length that requires a travelling formwork hanging from a girder that rests on three piers above the bridge span. This enabled the construction work to be carried out at large heights in relatively short time.



i Owner National Motorway Company, Hungary +++ General Contractor Viaduct Consortium Hídépítő Rt. - Strabag Rt., Hungary +++ Engineer Metrőber Kft, Hungary +++ Design Hídépítő Rt., Hungary +++ Consultant Pont Terv Rt., Hungary
DSI Unit DSI Austria, Salzburg, Austria
DSI Services Supply of DYWIDAG Multistrand Tendons (about 1,000 pc. MA 6815 and 3,400 pc. MA 6819, including equipment)

Bridges on the new Motorway from Zagreb to Split employ DSI Know-how

Bridge over the Guduča River, Motorway Zagreb-Split, Croatia

The Guduča bridge consists of two separate parallel structures, each for one motorway direction. The length of the bridge is 225 m with spans of 67 m + 96 m + 62 m. The piers have a height of 35 m and 45 m respectively; the width of each deck is 13.9 m. Each pre-stressed hollow box girder superstructure was constructed using the free cantilever method employing a total four DYWIDAG Form Travellers and Type 12, 15 and 19 x 0.62" DYWIDAG Post-Tensioning Strand Tendons.



i Owner CROATIAN MOTORWAY CO.Zagreb, Croatia +++ General Contractor KONSTRUKTOR-INŽENJERING d.d. Split, Croatia +++ Consultant "Rijeka Project", Croatia +++ Design Dipl. Ing. Mr. Rene Lustig, Croatia
DSI Unit DSI Group HQ Operations, Munich, Germany
DSI Services Supply of the DYWIDAG Post-Tensioning System, Type MA with 12, 15 and 19x0.62", Rental of Pre-stressing Equipment and Rental of two sets DYWIDAG Form Travellers

Santan Freeway Interchange,
Phoenix, AZ, USA

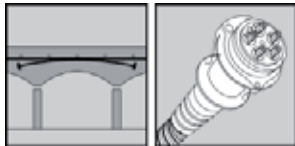

DYWIDAG Post-Tensioning Systems	4
Standard Strands	6
Corrugated Duct	7
PE/PP Round Duct	8
ETA Approvals	9
Anchorage	10
Installation	14
Stressing.....	16
Grouting.....	17
Plate Anchorage ED	18
Multiplane Anchorage MA	19
Coupler R	20
Coupler D	21
Loop Anchorage HV	22
Bond Head Anchorage ZF/ZR	23
Coupler M/ME (Floating Anchorage Block)	24
Plate Anchorage SD	25
Coupler P	26
Flat Anchorage FA	27
References	28
Equipment Overview	30
Calculation of Elongation	34
Addresses	36



DYWIDAG Post-Tensioning Systems

DYWIDAG Post-Tensioning Systems are world renowned for reliability and performance, most suitable for all applications in post-tensioned construction. They embrace the whole spectrum from bridge construction, buildings, to civil applications, above and underground.

The first ever structure built with a prototype DYWIDAG Post-Tensioning System using Bars was the arch-bridge Aisleben (Germany) in 1927. From that time on DYWIDAG has continuously improved its systems to keep up with the growing demand of modern construction technology. In addition to the traditional post-tensioning system using bars, that is mainly geared towards geotechnical applications, building rehabilitation and strengthening, DSI offers a complete product line in strand post-tensioning (bonded, unbonded and external) as well as stay-cables being able to fully serve the post-tensioning construction. DYWIDAG Post-Tensioning Systems have always combined highest safety and reliability standards with most economical efficiency in their research and development. Dependable corrosion protection methods of the DYWIDAG Post-Tensioning Systems contribute to the longevity of modern construction. High fatigue resistance is achieved with optimized material selection and cautious detailing of all the components especially in their system assembly.



Victory Bridge, NJ, USA



LNG Tanks, Sagunto, Spain





DSI Scope:

- consulting
- design and shop-drawing engineering
- manufacturing and supply
- installation or training and/or supervision of installation
- inspection and maintenance

We look back on many years of valuable experience in the field of post-tensioning which leads to our extremely versatile product range that offers economical solutions for practically any problem. This includes our highly developed, most sophisticated equipment which is easy to operate in all phases beginning with assembly, installation, stressing and finally grouting.

DYWIDAG Post-Tensioning Systems are being developed and maintained by DYWIDAG-Systems International and are serviced and distributed by a worldwide network of subsidiaries. Our systems comply with the international specifications and recommendations (ASTM, AASHTO, BS, Eurocode, DIN, Austrian Code, SIA, FIP, fib, EOTA, etc.). The American construction market demanded a product range that is described in separate brochures. The quality of the DSI products and services is in full compliance with ISO 9001.



Post-Tower, Bonn, Germany

Standard Strands

Strands are made from 7 individual cold-drawn wires, 6 helically wound outer wires and one center wire (king wire). The mechanical properties of the strand as well as corrosion protection properties are most important to DSI. Strands can be supplied either bare, galvanized or epoxy-coated without any loss in strength including the wedge anchorage. For a maximum in corrosion protection we offer electrically isolated systems using polyethylene (PE) or polypropylene (PP) ducts. See also page 8.



Strands are usually packaged in so-called coils that can weigh up to 3.5 tons.

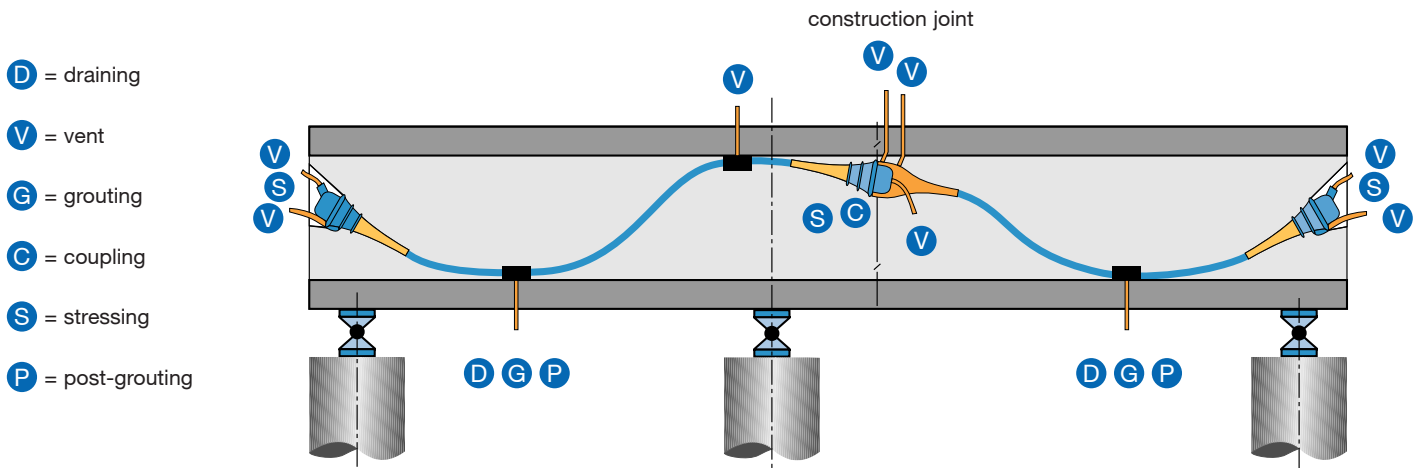
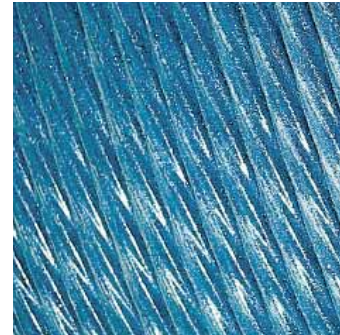

► Technical Data

type code/specification		13 mm (0.5")		15 mm (0.6")			
		ASTM A 416 Grade 270	prEN 10138 BS 5896	ASTM A 416 Grade 250	prEN 10138 BS 5896	ASTM A 416 Grade 270	prEN 10138 BS 5896
yield strength $f_{p0.1k}$	N/mm ²	1,670 ¹⁾	1,640 ²⁾	1,550 ¹⁾	1,560 ²⁾	1,670 ¹⁾	1,640 ²⁾
ultimate strength f_{pk}	N/mm ²	1,860	1,860	1,725	1,770	1,860	1,860
nom. diameter	mm	12.70	12.90	15.20	15.70	15.24	15.70
cross-sectional area	mm ²	98.71	100.00	139.40	150.00	140.00	150.00
weight	kg/m	0.775	0.785	1.094	1.180	1.102	1.18
ultimate load	kN	183.7	186.0	240.2	265.5	260.7	279.0
modulus of elasticity	N/mm ²	~195,000					
relaxation ³⁾ after 1,000 h at 0.7 x ultimate strength f_{pk}	%	max. 2.5					

¹⁾ yield measured at 1% effective elongation

²⁾ yield measured at 0.1% residual elongation

³⁾ applicable for relaxation class 2 according to Eurocode prEN 10138/BS 5896: or low relaxation complying with ASTM A 416, respectively.

Corrugated Duct

Metal ducts represent the most economical means to create a void for tensile elements. These thin-walled (0.25 - 0.60 mm), ribbed sheet metal ducts provide a fair secondary corrosion protection with excellent bond behavior between tendon and concrete. Primary corrosion protection is provided by the alkalinity of grout and concrete.

Dimensions of Corrugated Duct (Standard Sizes)

tendon type 0.5"	tendon type 0.6"	I.D. mm	sheathing	O.D. mm
5901	6801	20		25
5902	6802	40		45
5903	6803	50		55
5904	6804	55		60
5905	6805	60		65
5907	6806	65		70
5909	6807	65		70
5912	6809	75		80
5915	6812	80		85
5920	6815	90		95
5927	6819	95		100
5932	6822	100		105
5937	6827	110		118
-	6831	120		128
-	6837	130		138

The tendon type number (e.g. 5901, 6801) is composed as follows: the first digit (5 or 6) identifies the nominal strand diameter in tenth of inches, i.e. 0.5" or 0.6"/0.62", the last two digits (.01) reference the number of used strands (= 1 strand). The second digit is an internal code. As regards the 0.6" tendon types, the accessories fit both Grade 250 (GUTS 1770 N/mm²) and Grade 270 (GUTS 1860 N/mm²) strands.

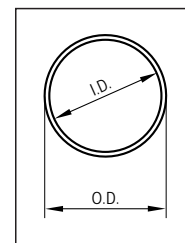
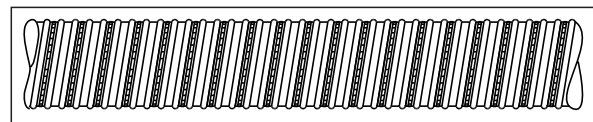

tendon type 0.5"	tendon type 0.6"	min. center distances ¹⁾ mm	support distances up to ¹⁾ m	wobble coefficient rad/m	friction coefficient rad ⁻¹
5901	6801	36	1.8	14 x 10 ⁻³	0.15
5902	6802	72	1.8	9 x 10 ⁻³	0.17
5903	6803	90	1.8	5 x 10 ⁻³	0.18
5904	6804	99	1.8	5 x 10 ⁻³	0.19
5905	6805	108	1.8	5 x 10 ⁻³	0.20
5907	6806	117	1.8	5 x 10 ⁻³	0.19
5909	6807	117	1.8	5 x 10 ⁻³	0.19
5912	6809	117	1.8	5 x 10 ⁻³	0.19
5915	6812	144	1.8	5 x 10 ⁻³	0.19
5920	6815	162	1.8	5 x 10 ⁻³	0.19
5927	6819	171	1.8	5 x 10 ⁻³	0.20
5932	6822	180	1.8	5 x 10 ⁻³	0.20
5937	6827	198	1.8	5 x 10 ⁻³	0.20
-	6831	216	1.8	5 x 10 ⁻³	0.20
-	6837	235	1.8	5 x 10 ⁻³	0.20

¹⁾ according to European Technical Approval

PE/PP Round Duct



Thick-walled polyethylene/polypropylene plastic ducts provide long-term secondary corrosion protection especially in aggressive environments such as in case of waste water treatment plants, acid tanks, silos or structures exposed to de-icing salts.

DYWIDAG-Systems International offers polyethylene/polypropylene ducts in straight lengths up to ≈ 24 m for all sizes. Standard shipping length is ≈ 12 m. Longer lengths in coils are available for all sizes except 130 mm.

Dimensions of Round Corrugated PE/PP Duct (Standard Size)

tendon type	tendon type	sheathing		wall thickness
		I.D.	O.D.	
0.5"	0.6"	mm	mm	mm
5907	6805	59	73	2
5909	6807	59	73	2
5912	6809	76	91	2.54
5915	6812	84	100	2.54
5920	6815	100	115	2.54
5927	6819	100	115	2.54
5937	6827	115	136	3.56
	6837	130	151	3.56

Flat PE/PP Duct

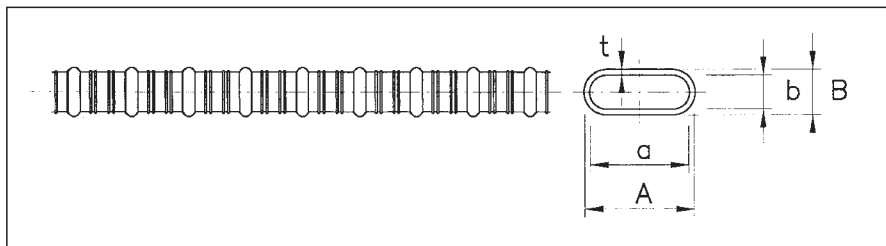

type	tendon type	A	B	a	b	wall thickness
	0.6"	mm	mm	mm	mm	mm
flat duct	6804	90.2	39.5	80	29	2



Construction products with an European Technical Approval (ETA) meet all essential demands given in the Construction Products Directive (CPD).

The ETA holder is authorized to apply the CE-marking (Conformité Européenne) on his product. The CE-marking certifies the conformity with the technical specification and is the basis for the free movement of goods within the EU member states.

DSI is proud to have European Technical Approvals for its PT-systems with bars, bonded strands and unbonded strands.

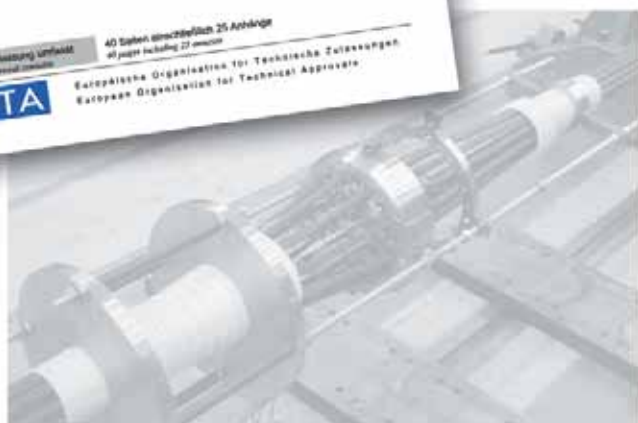

Plate Anchorage Type ED

The two-part plate anchorage can be used in slabs and similar structures, e.g. transversal prestressing in bridge decks. The wedge plate self-centers on

the anchor plate providing consistent assembly and installation as well as trouble-free stressing.

stressing anchorage	dead end anchorage accessible	not accessible
✓	✓	✓

ultimate load kN	
from	to
721	1.395



Multiplane Anchorage MA

The two-part multiplane anchorage is primarily used for longitudinal tendons in beams and bridges.

The wedge plate and the conical anchor body with usually three load transfer planes introduces the prestressing force continuously into the member with minimal front area.

The separation of anchor body and wedge plate makes it possible to insert the strand after casting the concrete. The wedge plate self-centers on the anchor body providing consistent assembly and installation as well as trouble-free stressing.



stressing anchorage	dead end anchorage accessible	not accessible
✓	✓	✓

ultimate load kN	
from	to
1,201	10,323

Coupler R

Coupler R is designed to couple on to already installed and stressed tendons. The coupler consists of a multiplane anchor body and a coupler wedge plate where the strands are overlapped. The continuing strands can be installed easily and independently.



fixed coupler
✓

floating coupler
-

ultimate load kN	
from	to
1,201	10,323

Coupler D

To lengthen unstressed tendons, e.g. in segmental bridge construction, coupler D is put to use. The splice chuck consists of two spring-loaded wedges that connect two strands individually.

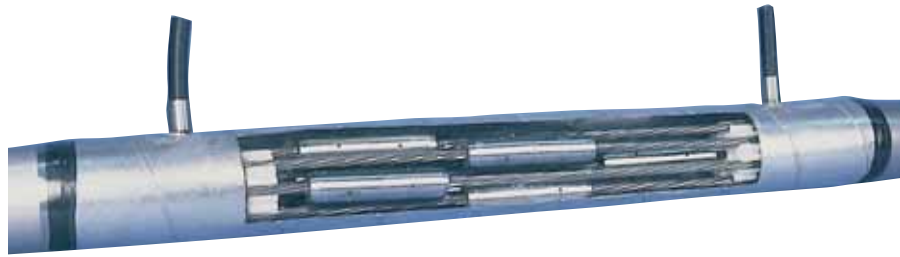

fixed coupler	floating coupler	ultimate load kN	
-	✓	from 721	to 10,323

Loop Anchorage HV

Often used in large plate-shaped structures, walls in off-shore structures or LNG tanks with generally static loadings. The 180° loop should be positioned in the center of the tendon to allow for non-slippage during simultaneous two-end stressing.



stressing anchorage	dead end anchorage accessible	dead end anchorage not accessible	ultimate load kN	
-	-	✓	from 721	to 6,138

Bond Head Anchorage ZF/ZR

Primarily used with prefabricated tendons, it is also possible to fabricate this anchorage on site. The strand wires are plastically deformed to ensure a safe load transfer up to ultimate capacity in the area of the bond head proven in static as well as in dynamic applications. Depending on the boundary conditions either a rather flat or a bulky bond head anchorage pattern is available.

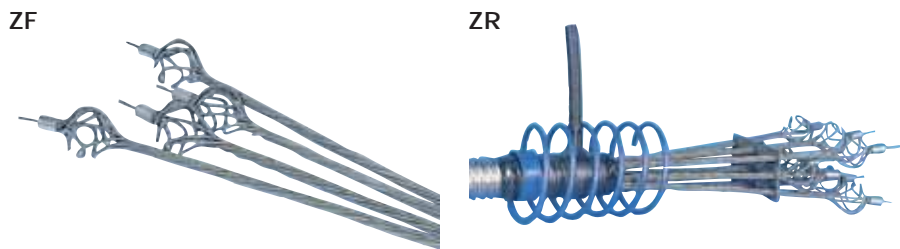

stressing anchorage	dead end anchorage accessible	dead end anchorage not accessible	ultimate load kN	
-	-	✓	from 721	to 6,138

Coupler M/ME (Floating Anchorage Block)

Rotation symmetric structures (water tanks, digester tanks, large pipes or dome shells) that require circumferential post-tensioning are the principal applications for the floating coupler M/ME. The tendon anchorage consists of an anchorage block with wedge holes on both sides to accept bare or greased and sheathed strands. The strands actually overlap in the block and use the belt-buckle principle. The ring-tendon is very compact and requires a very small pocket only.

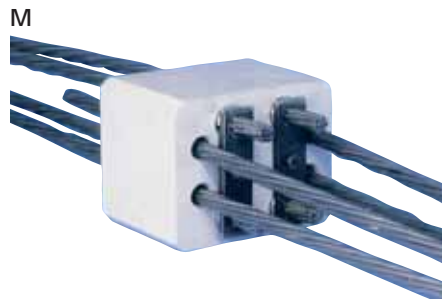

stressing anchorage	dead end anchorage accessible	anchorage not accessible	ultimate load kN	
✓	✓	-	from 240	to 3,348

Plate Anchorage SD

The single unit plate anchorage is designed for plate structures as well as transverse tendons in bridges. Small edge and center distances allow for an economical anchorage layout in condensed situations.

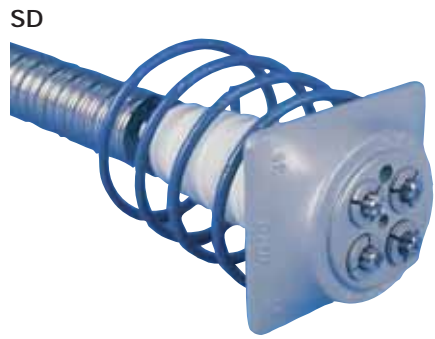

stressing anchorage	dead end anchorage accessible	anchorage not accessible	ultimate load kN	
✓	✓	✓	from 721	to 2,511

Coupler P

Coupler P consists of a multiplane anchor body, the standard wedge plate and a coupler ring that accepts the continuing strands with swaged anchorages instead of wedges. For similar applications both coupler R and P can be installed alternatively.

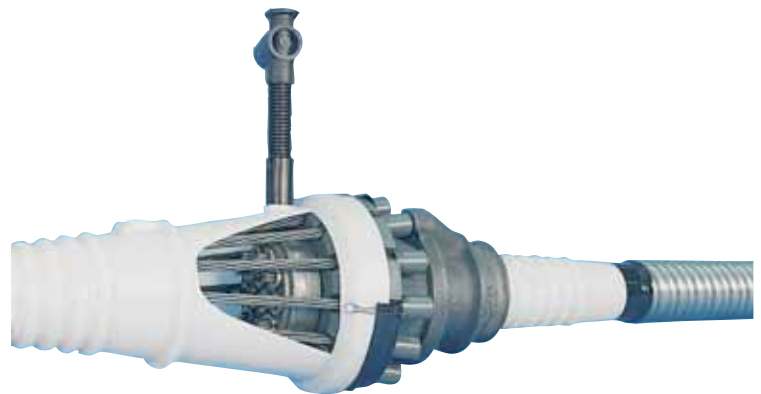

fixed coupler	floating coupler	ultimate load kN	
✓	-	from 1,201	to 10,323

Flat Anchorage FA

The Flat Anchorage of max. 4-0.62" strands in one plane to deviate into one oval duct is designed to be installed in thin members such as transverse post-tensioning of the top slab of box-girder bridges and prestressed flat slabs.



stressing anchorage	dead end anchorage accessible	dead end anchorage not accessible	ultimate load kN	
✓	✓	✓	from 721	to 1,116

Overview

Tendon Type 59...

	59...	01	02	03	04	05	06	07	08	09	12	15	20	27	32	37
Anchorage Type																
Plate Anchorage Type ED					●	●	●	●								
Multiplane Anchorage MA								●		●	●	●	●	●	●	●
Coupler R										●	●	●	●	●	●	●
Coupler D					●	●		●		●	●	●	●	●	●	●
Loop Anchorage HV					●	●	●	●		●	●	●	●	●		
Bond Head Anchorage ZF/ZR					●	●		●		●	●	●	●	●		
Plate Anchorage SD					●	●		●	●	●	●					
Flat Anchorage FA					●	●										

Other size tendons on request

Tendon Type 68...

	68...	01	02	03	04	05	06	07	08	09	10	12	15	19	22	27	31	37
Anchorage Type																		
Plate Anchorage Type ED				●	●	●												
Multiplane Anchorage MA						●		●		●		●	●	●	●	●	●	●
Coupler R						●		●		●		●	●	●	●	●	●	●
Coupler D				●	●	●		●		●		●	●	●	●	●	●	●
Loop Anchorage HV				●	●	●	●	●		●		●	●	●	●			
Bond Head Anchorage ZF/ZR				●	●	●		●		●		●	●	●	●			
Coupler M and ME (Floating Anchorage)	●	●		●		●		●		●		●						
Plate Anchorage SD				●	●	●	●	●	●	●								
Coupler P						●				●		●	●	●		●		
Flat Anchorage FA				●	●													

Other size tendons on request

Installation



DYWIDAG-Systems International has developed three different methods to insert strands into ducts. The selection of the insertion method depends on the boundary conditions of the structure and the job site.



Method 1: Pushing

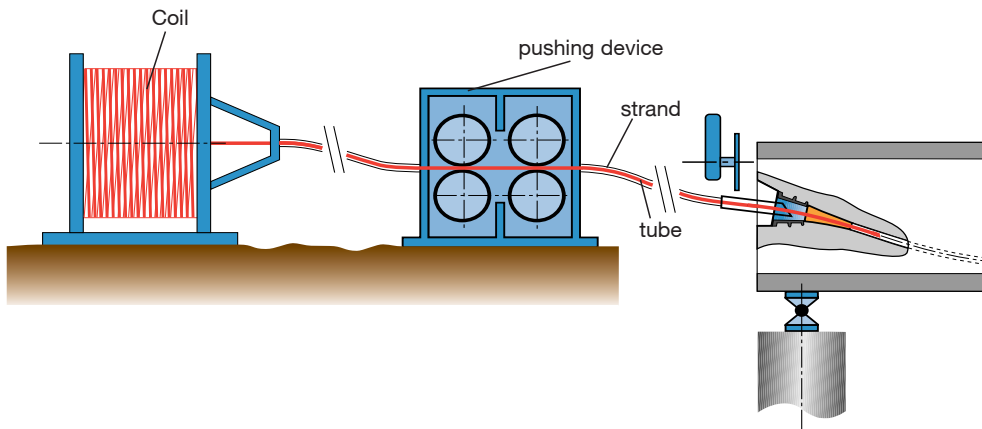

To push strands into the duct on the job site is very economical and can be done either before or after casting the concrete. The pushing equipment can be installed remotely and connected flexibly to the insertion point. DSI strand pushers provide relatively high speed of up to 8 m/s and require minimal operating personnel of only two men. These advantages make this method the preferred standard for strand installation.



Method 2: Pulling

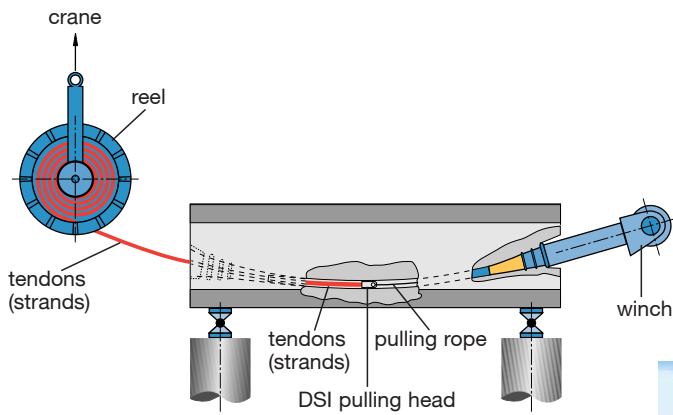

To install strands while pulling them into the duct can be very efficient in special structures, for example where the loop anchorage is used. In normal cases the whole bundle of strands is pulled through winching with a steel cable.



Method 3: Pre-Assembled Tendons



The prefabrication of tendons either in the shop or in the field can also be very economical, especially with shorter tendons and short shipping distances. Special uncoilers or hydraulic winches are necessary to properly install the tendons in the structure.



Stressing

DYWIDAG has developed a series of jacks, rams and hydraulic pumps in order to reach the target stressing load. The necessary versatility is provided by changing devices that make one unit adaptable for many different tendon sizes. DYWIDAG Equipment is designed to cover a wide spectrum of applications with jack capacities ranging from 250 kN up to 15,000 kN.

DYWIDAG Rams are highly sophisticated, but still convenient to operate. They employ inner tube bundles with automatic gripping devices that guide the strand safely through the inside of the ram. This feature allows the stressing operation to be controlled with the highest degree of reliability as well as minimal wedge seating losses by benefiting from the power seating option. Power seating is a way of hydraulically pressing in the wedges with a predefined load individually and simultaneously rather than relying simply on friction seating. DYWIDAG rams also make it possible to overstress and release the tendon to compensate for friction losses and maximize the stress level over the tendon length.

Every ram has a pressure relief valve for safety reasons that activates to limit hydraulic pressure should the hydraulic pump malfunction. To further verify the stressing operation an additional gauge port is provided directly on the ram.

Stressed tendons can be destressed with special wedges and a special ram configuration. Hydraulic pumps can be equipped with a convenient remote control device. Further information concerning the equipment is provided on page 30 and following.



919 . 6803 . 6801 5920



measurement of piston stroke



hydraulic pump with a remote control



venting operation

The durability of post-tensioned construction depends mainly on the success of the grouting operation. The hardened cement grout provides bond between concrete and tendon as well as primary long-term corrosion protection for the prestressing steel.

DYWIDAG has developed a grouting operation that is based on thixotropic and highly plasticized grout, and utilizes durable grouting equipment. Advanced methods such as pressure grouting, post-grouting and vacuum grouting are all results of many years of development.

Grouting is always done from a low-point of the tendon. This can be one of the anchorages where a grout cap with grout hose is the port for the grout or along the tendon utilizing an intermediate grout saddle. All grouting components are threaded for easy, fast and positive connection (see page 32 and following).



mixing and grouting unit



vacuum grouting

Plate Anchorage ED

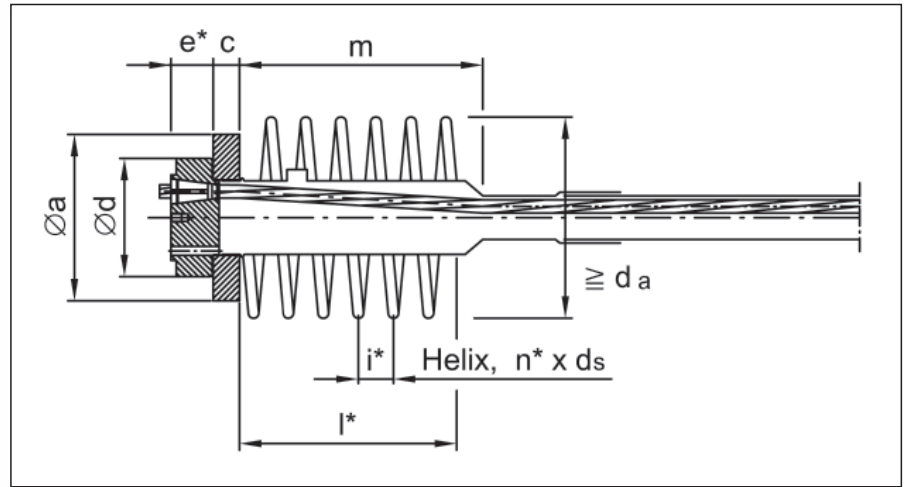

► Technical Data

type 0.5"	ultimate load Ø 12.9 mm f _{pk} 1860 (186 kN per strand)	type 0.6"	ultimate load Ø 15.7 mm f _{pk} 1860 (279 kN per strand)	Ød	Øa	e*	c	m
N/mm ²	kN	N/mm ²	kN	mm	mm	mm	mm	mm
5904	744	6803	837	110	165	47	30	170
5905	930	6804	1116	110	165	47	30	170
5907	1302	6805	1395	135	190	47	30	280

► Details of the Anchorage Zone for 35 N/mm² (cube) / 28 N/mm² (cylinder) Actual Concrete Strength at Stressing

Ø 12.9/15.2 mm, ultimate load 186/260.4 kN								Ø 15.7 mm, ultimate load 279 kN						
type 0.5"	type 0.6"	distances of the anchorages		additional reinforcement helix				type 0.6"	distances of the anchorages		additional reinforcement helix			
f _{pk} 1860	f _{pk} 1860	center distance	edge distance ¹⁾	Øda	min l*	n*	ds	f _{pk} 1860	center distance	edge distance ¹⁾	Øda	min l*	n*	ds
N/mm ²	N/mm ²	mm	mm	mm	mm	mm	mm	N/mm ²	mm	mm	mm	mm	mm	mm
5904	6803	190	115	150	175	5	14	6803	200	120	150	175	5	14
5905	6804	215	130	180	195	5	14	6804	225	135	180	195	5	14
5907	6805	240	140	205	195	5	14	6805	250	145	205	195	5	14

1) in case of 30 mm concrete cover

The values for the anchorage zones are based on European Technical Approval ETA-06/0022.

Center/edge distances and data for additional reinforcement for other actual concrete strengths and further assistance can be found on www.dywidag-systems.com

Max. prestressing load 75 % of ultimate load (GUTS) (short-term overstressing to 80 % is permissible)
The respective standards and regulations valid at the place of use shall be complied with.



Multiplane Anchorage MA

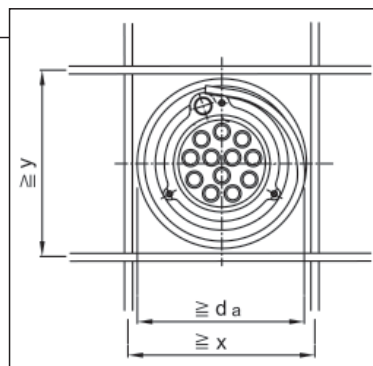
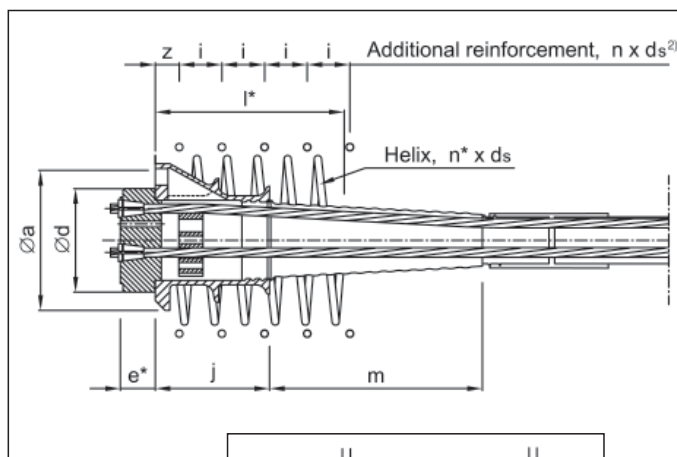

► Technical Data

type 0.5"	ultimate load \varnothing 12.9 mm f_{pk} 1860	type 0.6"	ultimate load \varnothing 15.7 mm f_{pk} 1860	$\varnothing d$	$\varnothing a$	e^*	j	m
N/mm ²	kN	N/mm ²	kN	mm	mm	mm	mm	mm
5907	1,302	6805	1,395	117	150	47	90	190
5909	1,674	6807	1,953	130	170	52	100	160
5912	2,232	6809	2,511	145	190	52	125	280
5915	2,790	6812	3,348	170	220	55	180	350
5920	3,720	6815	4,185	190	250	60	200	390
5927	5,022	6819	5,301	210	280	68	220	430
5932	5,952	6822	6,138	220	310	73	220	550
5937	6,882	6827	7,533	240	340	80	240	550
-	-	6831	8,649	270	420	80	350	550
-	-	6837	10,323	270	420	95	350	550

► Details of the Anchorage Zone for 40 N/mm² (cube) / 33 N/mm² (cylinder) Actual Concrete Strength at Stressing

Ø 12.9/15.2 mm, ultimate load 186/260.4 kN								Ø 12.9/15.7 mm, ultimate load 186/279 kN									
type 0.5"	type 0.6"	distances of the anchorage		additional reinforcement helix ²⁾				type 0.5"	type 0.6"	distances of the anchorage		additional reinforcement helix ²⁾					
f_{pk} 1860	f_{pk} 1860	center distance	edge distance ¹⁾	$\varnothing da$	min	l^*	n^*	ds	f_{pk} 1860	f_{pk} 1860	center distance	edge distance ¹⁾	$\varnothing da$	min	l^*	n^*	ds
N/mm ²	N/mm ²	mm	mm	mm	mm	mm	mm	mm	N/mm ²	N/mm ²	mm	mm	mm	mm	mm	mm	mm
5907	6805	220	130	200	270	4,5	14	-	6805	230	135	205	270	4,5	14	-	-
5909	6807	260	150	235	295	5	14	-	6807	270	155	240	295	5	14	-	-
5912	6809	295	170	250	320	5,5	16	-	6809	305	175	260	320	5,5	16	-	-
5915	6812	345	195	290	365	6,5	16	-	6812	355	200	300	365	6,5	16	-	-
5920	6815	385	215	340	385	7	16	-	6815	395	220	350	385	7	16	-	-
-	6819	430	235	390	410	7,5	16	5927	6819	445	245	400	410	7,5	16	-	-
-	6822	470	255	430	445	7,5	16	5932	6822	485	265	440	445	7,5	16	-	-
5937	6827	525	285	450	460	7	20	-	6827	540	290	460	460	7	20	-	-
-	6831	570	305	510	615	9	20	-	6831	590	315	530	615	9	20	-	-
-	6837	630	335	550	615	9	20	-	6837	650	345	570	615	9	20	-	-

1) in case of 30 mm concrete cover 2) additional surface reinforcement acc. to ETA-06/0022 is required.

The values for the anchorage zones are based on European Technical Approval ETA-06/0022.

Center/edge distances and data for additional reinforcement for other actual concrete strengths and further assistance can be found on www.dywidag-systems.com

Max. prestressing load 75 % of ultimate load (GUTS) (short-term overstressing to 80 % is permissible)
The respective standards and regulations valid at the place of use shall be complied with.



Coupler R

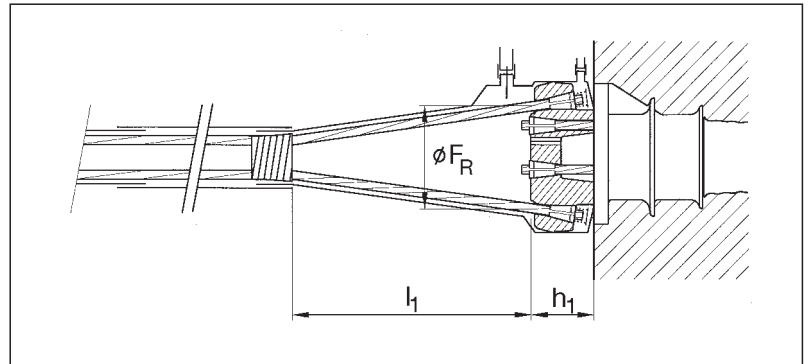

► Technical Data

type 0.5"	ultimate load ϕ 12.9 mm (186 kN per strand) f_{pk} 1860	ϕd	ϕF_R	h_1	l_1
N/mm ²	kN	mm	mm	mm	mm
5909	1,674	224	168	105	350
5912	2,232	224	172	105	350
5915	2,790	246	191	105	500
5920	3,720	264	215	110	450
5927	5,022	320	262	120	570
5932	5,952	340	279	125	640
5937	6,882	380	318	135	660

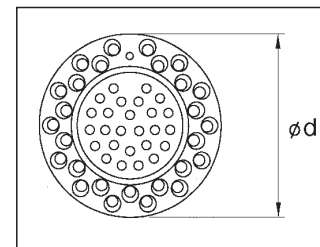

► Details of the Coupler Zone

type 0.6"	ultimate load ϕ 15.7 mm (279 kN per strand) f_{pk} 1860	ϕd	ϕF_R	h_1	l_1
N/mm ²	kN	mm	mm	mm	mm
6805	1,395	207	152	105	460
6807	1,953	207	152	105	370
6809	2,511	224	168	105	350
6812	3,348	246	188	105	500
6815	4,185	264	207	110	450
6819	5,301	289	224	120	570
6822	6,138	340	276	125	640
6827	7,533	380	314	135	660
6831	8,649	435	370	158	870
6837	10,323	435	370	158	870

ϕ 12.9 mm, ultimate load 186 kN			
type 0.5"	minimum center distance of Coupler R	minimum edge distance of Coupler R	length of space for installation
f_{pk} 1860	mm	mm	mm
N/mm ²			
5909	330	190	1500
5912	330	190	1500
5915	350	200	1500
5920	370	210	1500
5927	430	240	1700
5932	450	250	1700
5937	490	270	1700

The center/edge distances and additional reinforcement for Coupler R are identical with those of the corresponding MA-anchorage.

Due to geometrical constraints the center/edge distances must not fall below the minimum values given in the tables.

ϕ 15.7 mm, ultimate load 279 kN			
type 0.6"	minimum center distance of Coupler R	minimum edge distance of Coupler R	length of space for installation
f_{pk} 1860	mm	mm	mm
N/mm ²			
6805	310	180	1500
6807	310	180	1500
6809	330	190	1500
6812	350	200	1500
6815	370	210	1500
6819	400	225	1700
6822	450	250	1700
6827	490	270	1700
6831	550	300	2000
6837	550	300	2000



Coupler D

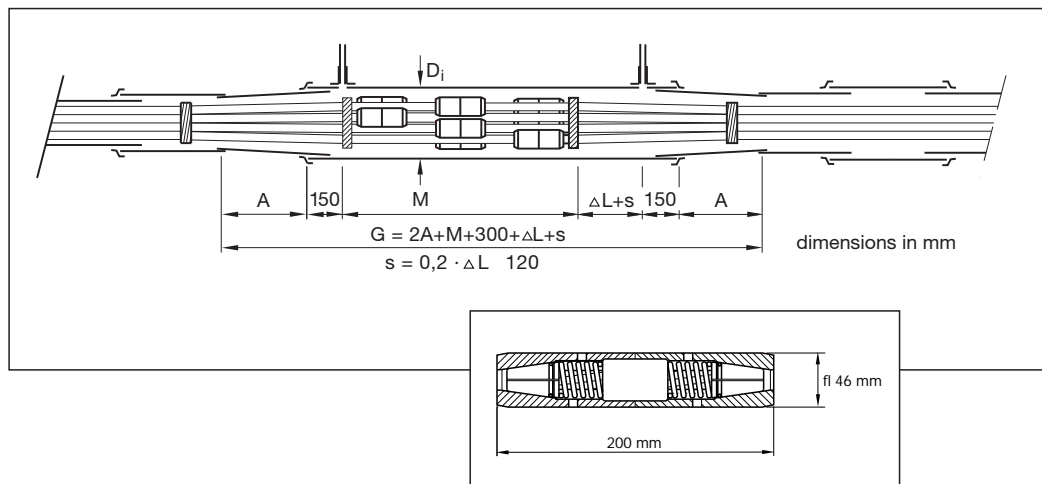
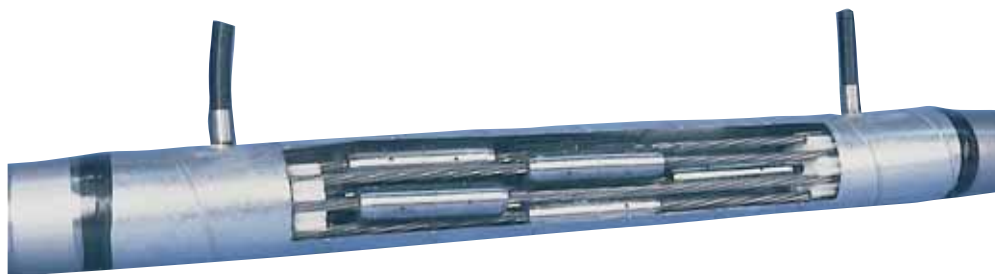

► Technical Data

type 0.5"	ultimate load Ø 12.9 mm f_{pk} 1860 (186 kN per strand)	type 0.6"	ultimate load Ø 15.7 mm f_{pk} 1860 (279 kN per strand)	A	M	Ø D_i
N/mm ²	kN	N/mm ²	kN	mm	mm	mm
-	-	6803	837	150	900	100
5904	744	6804	1,116	200	600	110
5905	930	6805	1,395	250	900	120
5907	1,302	6807	1,953	300	900	125
5909	1,674	6809	2,511	350	900	140
5912	2,232	6812	3,348	450	900	160
5915	2,790	6815	4,185	500	900	180
-	-	6819	5,301	550	940	200
5920	3,720	6822	6,138	700	940	225
5927	5,022	6827	7,533	700	940	225
5932	5,952	6831	8,649	800	940	250
5937	6,882	6837	10,323	800	940	250

► Details of the Coupler Zone

Ø 12.9/15.7 mm, ultimate load 186/279 kN

type 0.5"	type 0.6"	center distances coupler to coupler	center distances duct to coupler
f_{pk} 1860 N/mm ²	f_{pk} 1860 N/mm ²	mm	mm
-	6803	180	135
5904	6804	195	150
5905	6805	210	160
5907	6807	220	170
5909	6809	245	195
5912	6812	270	210
5915	6815	300	235
-	6819	325	255
5920	6822	365	280
5927	6827	375	295
5932	6831	420	325
5937	6837	420	335



Loop Anchorage HV

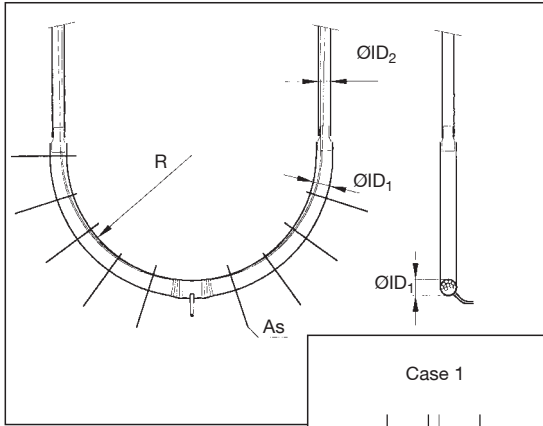

Additional Reinforcement

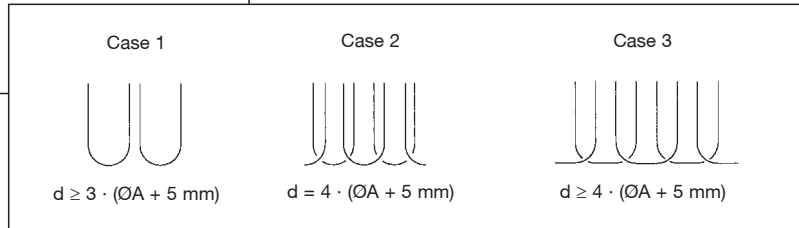
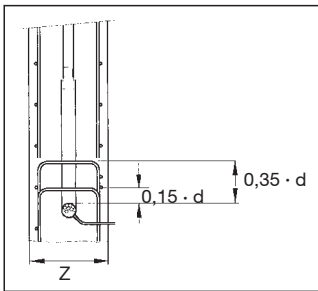

► Technical Data

type	ultimate load	type	ultimate load	ID ₁	ID ₂
0.5"	Ø 12.9 mm	0.6"	Ø 15.7 mm		
f_{pk}	(186 kN per strand)	f_{pk}	(279 kN per strand)		
1860		1860			
N/mm ²	kN	N/mm ²	kN	mm	mm
5904	744	6803	837	50	40
5905	930	6804	1,116	55	45
5907	1,302	6805	1,395	60	50
5909	1,674	6807	1,953	75	60
5912	2,232	6809	2,511	85	75
5915	2,790	6812	3,348	95	80
5920	3,720	6815	4,185	110	90
5927	5,022	6819	5,301	120	95
5932	5,952	6822	6,138	130	100

► Details of the Anchorage Zone for 28 N/mm² (cube) / 23 N/mm² (cylinder) Actual Concrete Strength at Stressing

Ø 12.9/15.2 mm, ultimate load 186/260.4 kN			
type	type	R	As
0.5"	0.6"		
f_{pk}	f_{pk}		
1860	1860		
N/mm ²	N/mm ²	mm	cm ²
5904	6803	600	12,5
5905	6804	600	16,5
5907	6805	650	21,0
5909	6807	750	29,0
5912	6809	900	37,5
5915	6812	1100	50,0
5920	6815	1250	62,5
5927	6819	1500	79,0
5932	6822	1700	91,5

Ø 15.7 mm, ultimate load 279 kN		
type	R	As
0.6"		
f_{pk}		
1860		
N/mm ²	mm	cm ²
6803	600	13,5
6804	600	18,0
6805	700	22,0
6807	800	31,0
6809	950	40,0
6812	1150	53,5
6815	1350	67,0
6819	1600	85,0
6822	1800	98,0

The radii given in the above tables apply for smooth metal duct. For corrugated metal duct the radius values must be doubled. Ducts need to be pre-bent.

The values for the loop anchorage dimensions are based on European Technical Approval ETA-06/0022.

Application only in concrete members subject to static action. Tendons need to be stressed simultaneously at both ends.



Bond Head Anchorage ZF/ZR

ZF

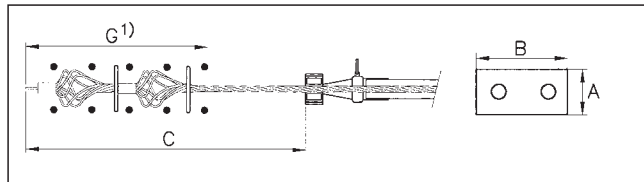

1) additional surface reinforcement in area G required

► Technical Data

type 0.5" f _{pk} 1860 N/mm ²	ultimate load Ø 12.9 mm (186 kN per strand) kN	type 0.6" f _{pk} 1860 N/mm ²	ultimate load Ø 15.7 mm (279 kN per strand) kN	A mm	B mm	C mm
–	–	6803	837	220	360	1000
5904	744	6804	1,116	230	430	1000
5905	930	6805	1,395	280	280	1000
5907	1,302	6807	1,953	330	280	1000
5909	1,674	6809	2,511	280	380	1000
5912	2,232	6812	3,348	330	380	1000
5915	2,790	6815	4,185	380	380	1000
5920	3,720	6819	5,301	480	380	1000

ZR

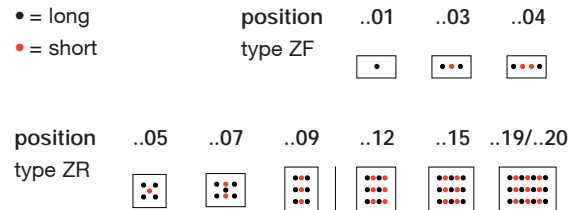
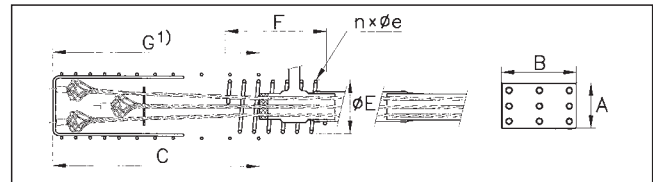
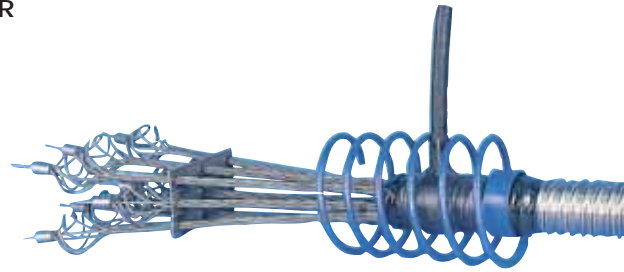

► Details of the Anchorage Zone for 40 N/mm² (cube) / 33 N/mm² (cylinder) Actual Concrete Strength at Stressing

type 0.5" f _{pk} 1860 N/mm ²	type 0.6" f _{pk} 1770 N/mm ²	distances of the anchorages		additional reinforcement helix			
		center distances mm	edge distances mm	E mm	F mm	n	e mm
–	6803	220/360	110/180	–	–	–	–
5904	6804	230/430	115/215	–	–	–	–
5905	6805	280/280	160/160	200	300	5	10
5907	6807	280/330	160/185	200	300	5	10
5909	6809	380/280	210/160	200	300	5	10
5912	6812	380/330	210/185	200	300	5	12
5915	6815	380/380	210/210	200	300	5	14
5920	6819	380/480	210/260	200	350	6	14

type 0.6" f _{pk} 1860 N/mm ²	distances of the anchorages		additional reinforcement helix			
	center distances mm	edge distances mm	E mm	F mm	n	e mm
6803	220/400	110/200	–	–	–	–
6804	240/480	110/180	–	–	–	–
6805	280/280	160/160	200	300	5	10
6807	280/330	160/185	200	300	5	12
6809	380/280	210/160	200	300	5	12
6812	380/330	210/185	200	300	5	14
6815	380/380	210/210	200	300	5	16
6819	380/480	210/260	200	350	6	16

The values for the anchorage zones are based on requirements of FIP.

Max. prestressing load 75 % of ultimate load (GUTS) (short-term overstressing to 80 % is permissible).

The respective standards and regulations valid at the place of use shall be complied with.

Coupler M/ME (Floating Anchorage Block)

Coupler M

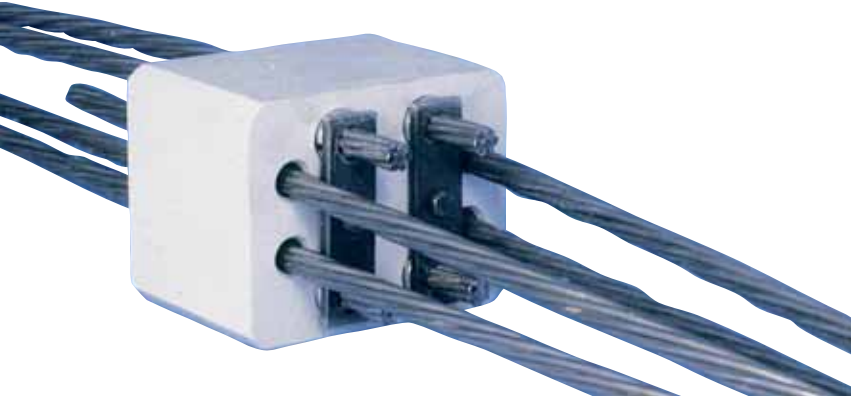

Coupler ME

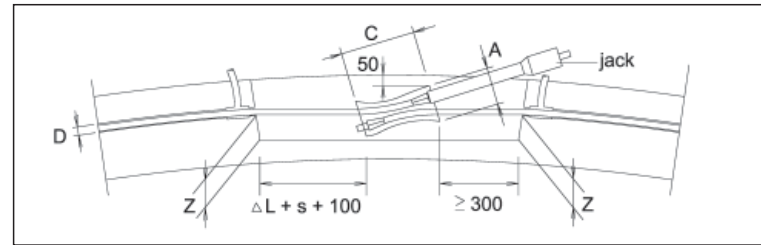
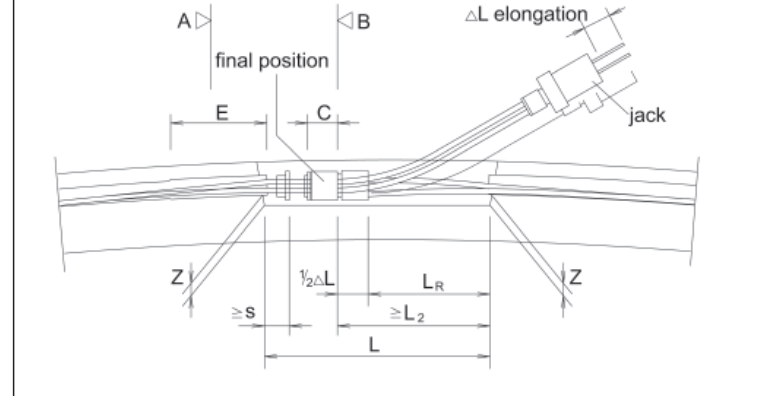
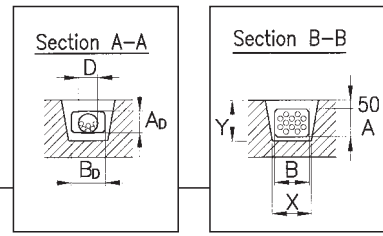
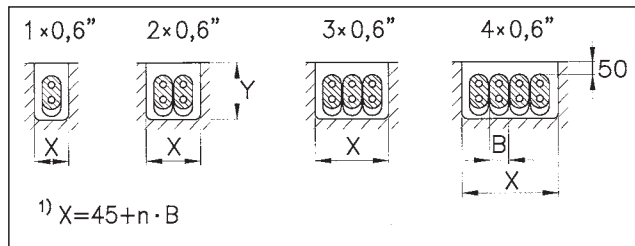

► Technical Data

type 0.6"	ultimate load Ø 15,7 mm (265 kN per strand)	ultimate load Ø 15,7 mm (279 kN per strand)	A	B	C	D	A _D	B _D	E
N/mm ²	kN	kN	mm	mm	mm	mm	mm	mm	mm
6801	265	279	98	55	200	20	-	-	-
6802	530	558	90	105	120	40	60	70	200
6804	1,060	1,116	130	160	120	55	70	130	650
6806	1,590	1,674	130	160	120	65	70	130	650
6808	2,120	2,232	130	210	120	75	70	170	1,050
6810	2,650	2,790	168	210	120	80	100	170	1,150
6812	3,180	3,348	168	210	120	80	100	170	1,150

Case 1: If $L_R \leq L_2 - \frac{1}{2} \Delta L$
then $L = s + 285 \text{ mm} + L_2$

Case 2: If $L_R > L_2 - \frac{1}{2} \Delta L$
then $L = s + 285 \text{ mm} + L_2 + \frac{1}{2} \Delta L$

$s = 0.2 \times \frac{1}{2} \Delta L \geq 120 \text{ mm}$

Max. prestressing load 70 % of ultimate load (GUTS) (short-term overstressing to 75 % is permissible).
The respective standards and regulations valid at the place of use shall be complied with.

► Details of Anchorage Zone

Ø 15,7 mm, ultimate load
265/279 kN

type 0.6"	X	Y	Z
mm	mm	mm	mm
6801	100	180	60
6802	130	155	50
6804	180	195	70
6806	180	195	70
6808	230	195	70
6810	230	235	90
6812	230	235	90

► Block-Out Dimensions

type 0.6"	L ₂	L _R
mm	mm	mm
6801	-	-
6802	550	550
6804	700	600
6806	700	600
6808	1,350	600
6810	1,500	800
6812	1,500	800

Plate Anchorage SD

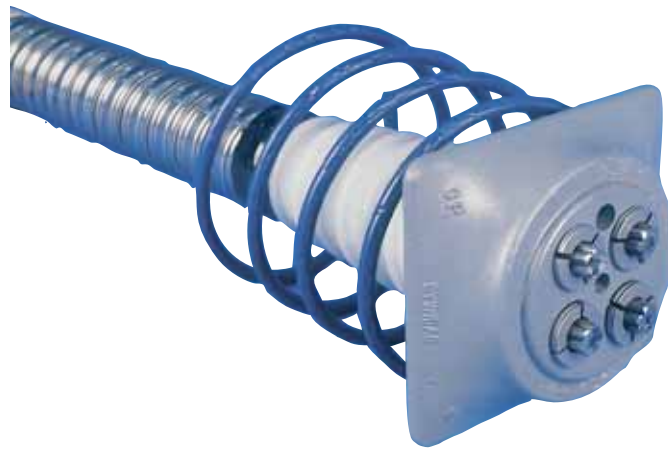
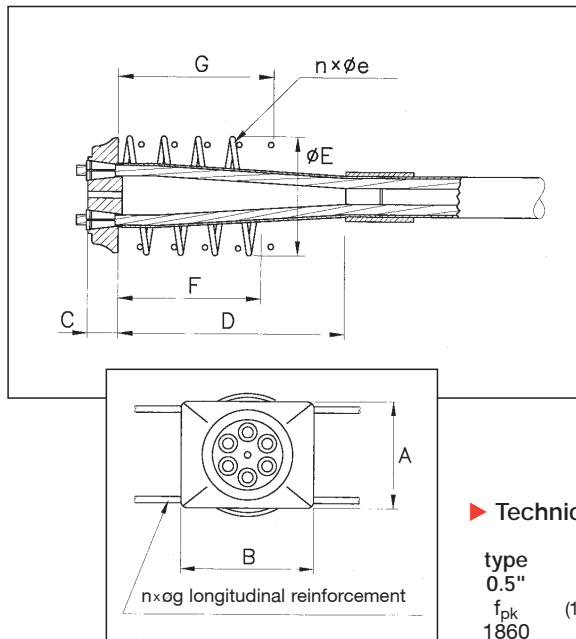

► Technical Data

type 0.5"	ultimate load Ø 12.9 mm f_{pk} 1860	type 0.6"	ultimate load Ø 15.7 mm f_{pk} 1860	A	B	C	D
N/mm ²	kN	N/mm ²	kN	mm	mm	mm	mm
5904	744	6803	837	125	140	41	200
5905	930	6804	1,116	135	160	41	200
5907	1,302	6805	1,395	150	180	40	300
5909	1,674	6807	1,953	170	215	44	270
5912	2,232	6809	2,511	190	245	48	325

► Details of the Anchorage Zone for 32 N/mm² (cube) / 27 N/mm² (cylinder) Actual Concrete Strength at Stressing

Ø 12.9/15.7 mm, ultimate load 186/265 kN

type 0.5"	type 0.6"	distances of the anchorage		additional reinforcement						
		center distances	edge distances	helix			long. bars			
f_{pk} 1860	f_{pk} 1770	mm	mm	E	F	n	e	G	n	g
N/mm ²	N/mm ²	mm	mm	mm	mm		mm	mm		mm
5904	6803	190/320	115/180	140	200	3	10	229	4	12
5905	6804	200/360	120/200	150	200	3	10	289	5	12
5907	6805	210/390	125/205	160	200	3	10	290	5	12
5909	6807	240/460	140/250	190	250	4	10	296	6	12
5912	6809	320/480	180/260	260	250	4	12	292	6	14

Ø 15.7 mm, ultimate load 279 kN

type 0.6"	distances of the anchorage		additional reinforcement						
	center distances	edge distances	helix			long. bars			
f_{pk} 1860	mm	mm	E	F	n	e	G	n	g
N/mm ²	mm	mm	mm	mm		mm	mm		mm
6803	200/320	120/180	140	250	4	10	229	4	12
6804	215/360	130/200	150	250	4	10	289	5	12
6805	230/390	135/205	160	250	4	10	290	5	12
6807	260/460	150/250	190	250	4	12	296	6	14
6809	340/480	190/260	260	300	5	14	292	6	16

The values for the anchorage zones are based on requirements of FIP.

Max. prestressing load 75 % of ultimate load (GUTS) (short-term overstressing to 80 % is permissible).

The respective standards and regulations valid at the place of use shall be complied with.

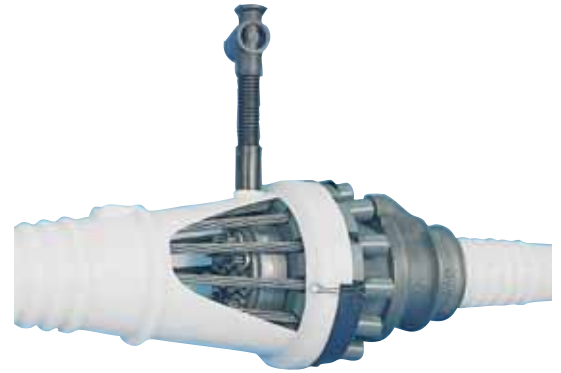
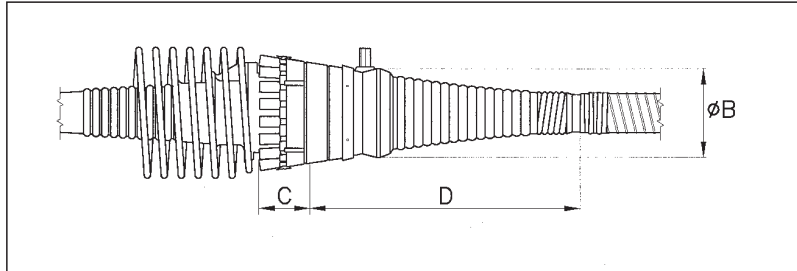

► Technical Data

type 0.6" f_{pk} 1860 N/mm ²	ultimate load Ø 15.7 mm (279 kN per strand)	A	B	C	D
		mm	mm	mm	mm
6805	1,395	176	115	132	510
6809	2,511	236	205	136	570
6812	3,348	260	225	145	755
6815	4,185	290	250	150	755
6819	5,301	305	265	155	880
6827	7,533	365	320	170	905

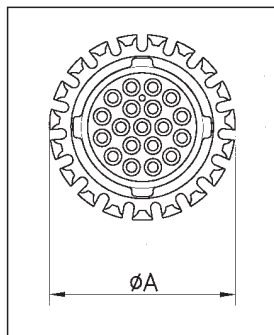

► Details of the Coupler Zone

Ø 15.7 mm, ultimate load 279 kN

type 0.6" f_{pk} 1860 N/mm ²	minimum center distance of Coupler P	minimum edge distance of Coupler P	length of space for installation
	mm	mm	mm
6805	280	170	1600
6809	340	200	1600
6812	370	215	1800
6815	400	230	1800
6819	420	240	2000
6827	480	270	2000

The center/edge distances and additional reinforcement for Coupler P are identical with those of the corresponding MA-anchorage.

Due to geometrical constraints the center/edge distances must not fall below the minimum values given in the tables.

Flat Anchorage FA

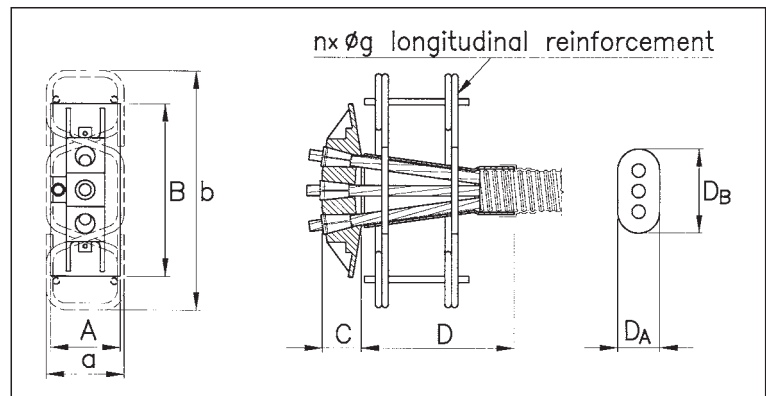
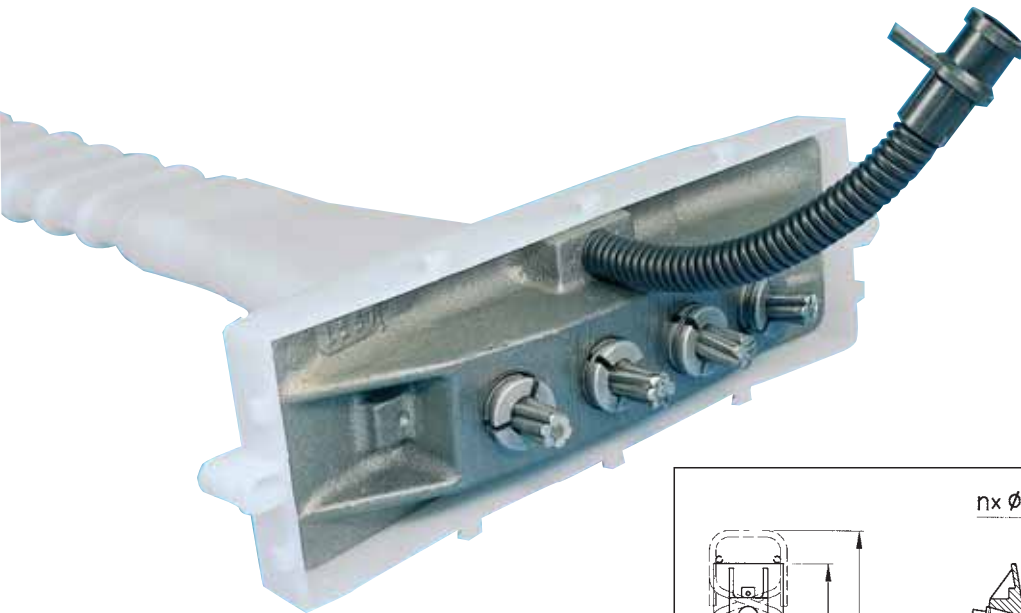

► Technical Data

type 0.5"	ultimate load Ø 12.9 mm f_{pk} 1860	type 0.6"	ultimate load Ø 15.7 mm f_{pk} 1860	A	B	C	D	D_A	D_B
N/mm ²	kN	N/mm ²	kN	mm	mm	mm	mm	mm	mm
–	–	6803	837	100	255	57	152	21	72
5904	744	6804	1,116	100	330	57	220	21	72

► Details of the Anchorage Zone for 40 N/mm² (cube) / 33 N/mm² (cylinder) Actual Concrete Strength at Stressing

Ø 12.9/15.7 mm, ultimate load 186/265 kN							Ø 15.7 mm, ultimate load 279 kN					
type 0.5"	type 0.6"	distances of the anchorage		additional reinforcement stirrups			type 0.6"	distances of the anchorage		additional reinforcement helix		
f_{pk} 1860	f_{pk} 1770	center distances	edge distances	a x b mm	n	g mm	f_{pk} 1860	center distances	edge distances	a x b mm	n	g mm
N/mm ²	N/mm ²	mm	mm	mm		mm	N/mm ²	mm	mm	mm		mm
–	6803	305	105	160/280	4	10	6803	320	105	160/280	4	10
5904	6804	380	105	180/360	4	12	6804	400	105	180/360	4	12

The values for the anchorage zones are based on requirements of FIP.

Max. prestressing load 75 % of ultimate load (GUTS) (short-term overstressing to 80 % is permissible).

The respective standards and regulations valid at the place of use shall be complied with.

DYWIDAG Technology is incorporated into Jordan's largest Wastewater Treatment Plant

As-Samra Wastewater Treatment Plant, Greater Amman Area, Jordan



i Owner Ministry of Water and Irrigation, The Hashemite Kingdom of Jordan +++ General Contractor and Consultant Consortium of The Morganti Group, Inc., USA and Infilco Degremont, Inc., USA
DSI Unit DSI Group HQ Operations, Munich, Germany
DSI Services Supply of 560 t DYWIDAG Post-Tensioning Systems, Type MA 5 and 9x0.6", Rental of Prestressing Equipment and Technical Assistance for Installation

DYWIDAG Bar and Strand Tendons for the High Speed Railway Line from Milan to Bologna, Italy



i Owner TAV, Treno Alta Velocità SPA, Rome, Italy +++ Main Contractor Cepav Uno, Consorzio Eni per l'alta velocità, San Donato Milanese, Milan, Italy +++ Contractor MODENA Scarl, San Donato Milanese, Milan, Italy +++ Subcontractor Impresa PIZZAROTTI & C. SPA, Parma, Italy
DSI Unit DYWIT SPA, Milan, Italy
Supply of JV ALGA SPA-DYWIT SPA Supply of 30,200 pcs. 12x0.6" strand anchorages; about Ø 40 mm 1,040 t Threadbars St 950/1050 with accessories; rental of equipment as well as technical support

DYWIDAG Strand Tendons for Interstate Bridge over the Pipa River

A10 interstate near Arruda dos Vinhos, Portugal



i Owner BRISA - Autoestradas de Portugal +++ Main Contractor CONDURIL Construtora Duriense, S.A., Portugal +++
Design Armando Rito, Portugal

DSI Unit DSI Portugal, Lisbon, Portugal

DSI Services Supply of DYWIDAG Strand Tendons including 344 MA anchorages type 12, 152 MA anchorages type 15 and 3,710 MA anchorages type 19; Rental of technical equipment

DYWIDAG Post-Tensioning Systems secure Railroad Bridges as Part of the High Speed Line from Brussels to Cologne

Construction of the eastern high-speed line (HSL) across the plateau of Herve parallel to the E40, Belgium



i Client SNCB Societe Nationale de Chemin fer Belge, Belgium +++ Main Contractor JV Entreprises Generales Louis Duchene S.A., Belgium; Maurice Delens, Brussels, Belgium; Van Rymenant, Brussels, Belgium +++ Consulting Engineers TUC Rail S.A., Brussels, Belgium

DSI Unit DSI Belgium, Boortmeerbeek, Belgium

DSI Services Supply and installation of 1,286 t post-tensioning systems 13-19x0.6"; Technical assistance

Equipment Overview

Jacks

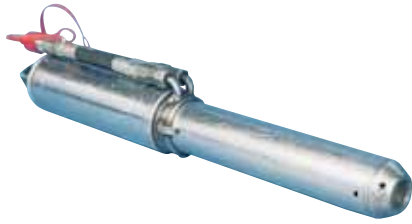

SM 240



HoZ 950/1,700



HoZ 3,000/5,400

jack type	59 ..														68 ..																		
	01	02	03	04	05	06	07	08	09	12	15	20	27	32	37	01	02	03	04	05	06	07	08	09	10	12	15	19	22	27	31	37	
SM 240	•															•																	
HoZ 950/100		•	•	•	•											•	•	•															
HoZ 1,700/150						•	•	•	•								•	•	•		•	•	•										
HoZ 3,000/250										•	•											•	•	•	•								
HoZ 5,400/250												•	•												•	•	•						
6,800														•	•														•	•			
9,750																																•	•

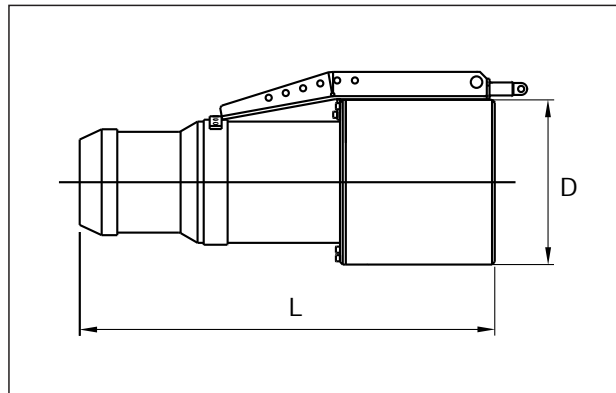

► Technical Data

jack type ¹⁾	length L mm	diameter D mm	stroke mm	piston area cm ²	capacity ²⁾ kN	weight kg
SM 240	842	98	200	47.13	240	19
HoZ 950/100	621	203	100	161.98	972	65
HoZ 1,700/150	803	280	150	298.45	1,745	160
HoZ 3,000/250	1,137	385	250	508.94	3,054	400
HoZ 5,400/250	1,271	482	250	894.57	5,367	600
6,800	1,150	560	300	1237.01	6,803	1,185
9,750	1,170	680	300	1772.45	9,748	1,770

¹⁾ power seating incl.

²⁾ without friction

Equipment Overview

Block-Out-Dimensions

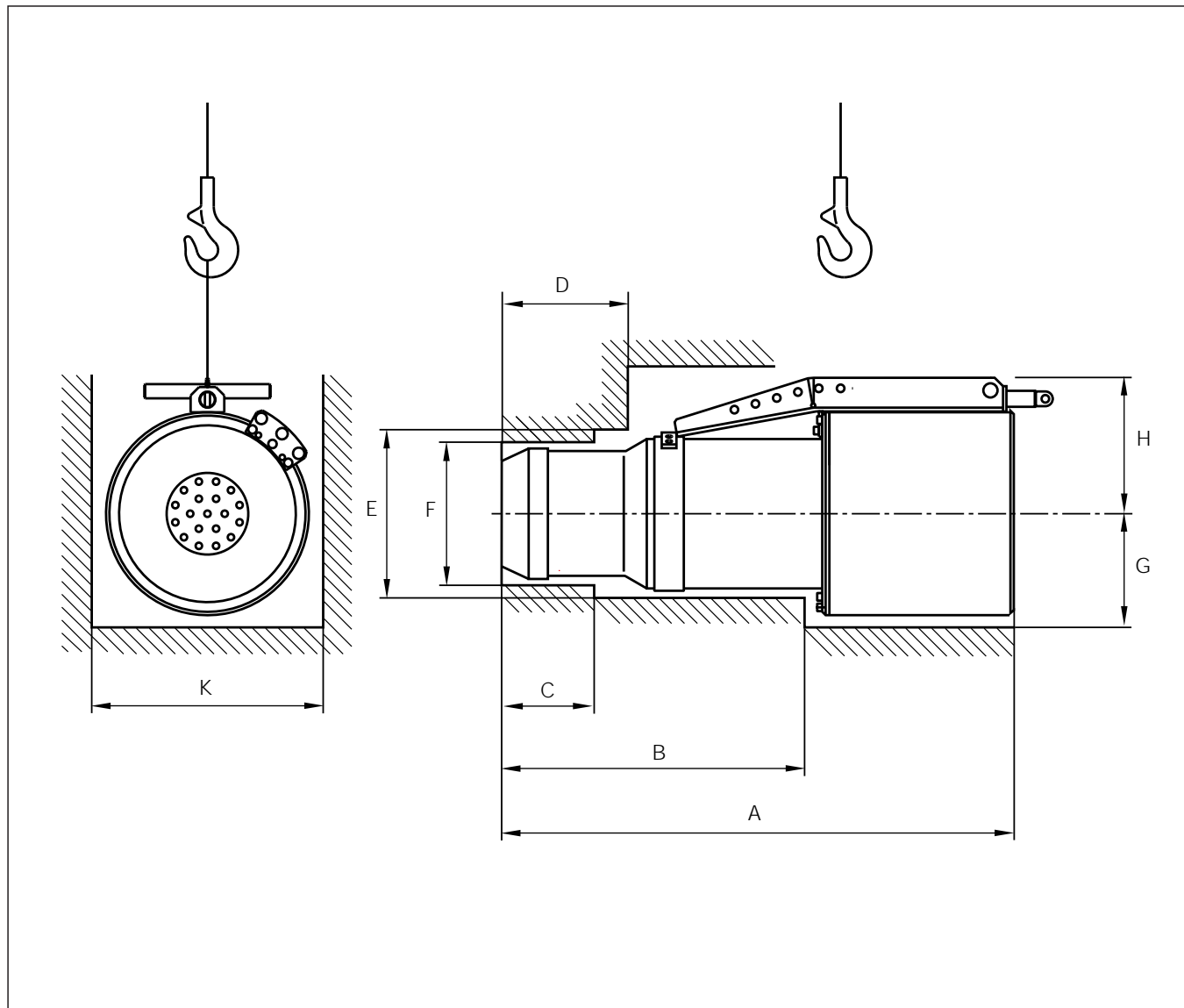

jack type	A	B	C	D	E	F	G	H	K	L ²⁾
SM 240	880 ¹⁾	370	-	80	100	75	50	120	100	230/270
HoZ 950/100	621	350	150	-	220	200	130	190	260	300/400
HoZ 1,700/150	803	490	180	-	270	230	170	220	340	450/600
HoZ 3,000/250	1,130	650	220	300	360	320	220	310	440	350/600
HoZ 5,400/250	1,235	740	220	300	420	360	270	320	540	450/800
6,800	1,421 ¹⁾	-	80	-	-	330	310	410	620	- /1,200
9,750	1,470 ¹⁾	-	120	-	-	380	390	550	740	- /1,200

¹⁾ stroke incl.

²⁾ nec. strand protrusion (without/with power seating device)

Equipment Overview

Hydraulic Pumps



77 - 159 A



R 6.4



R 11.2 - 11.2/210

	jacks	SM 240	HoZ 950	HoZ 1,700	HoZ 3,000	HoZ 5,400/250	6,800	9,750	15,000
pumps									
77 - 159 A ¹⁾		●	●						
77 - 193 A		●	●	●					
R 3.0		●	●	●					
R 6.4		●	●	●	●				
R 11.2-11.2					●	●	●		
R 11.2-11.2/210						●	●	●	●
ZP 57/28									
									for all pushing devices

¹⁾ for jacks without power seating

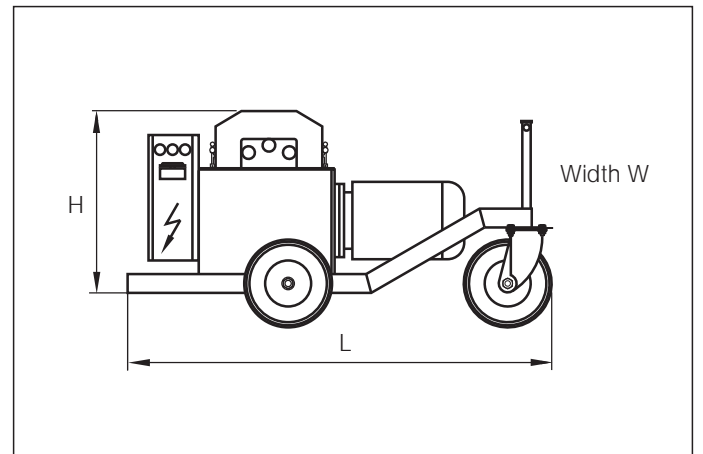
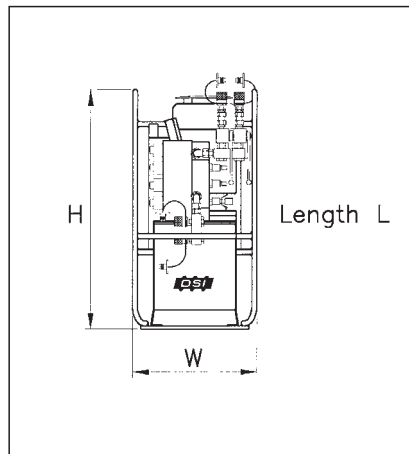

► Technical Data

pumps ¹⁾	operation pressure MPa	capacity V min l/min	eff. oil amount l	weight kg	dimensions L x W x H mm
77-159 A	70	3.0	10.0	60	420/380/480
77-193 A	70	3.0	10.0	63	420/380/480
R 3.0	70	3.0	13.0	98	600/390/750
R 6.4	60	6.4	70.0	310	1,400/700/1,100
R 11.2-11.2/210	55 (60)	11.2/22.4	170.0	720	2,000/800/1,300
ZP 57/58	16/22	53/80	175.0	610	1,260/620/1,330

¹⁾ hydraulic pumps will be delivered without oil

Pushing Equipment



ESG 8 - 1

type	tensile or compressive force kN	pushing speed m/s	weight kg	dimensions L x W x H mm	hydraulic pumps -
ESG 8 - 1	3.9	6.1	140	1,400/350/510	ZP 57/28

Grouting Equipment (mixing and pumping)



MP 2,000 - 5



MP 4,000 - 2

grouting equipment	max injection pressure MPa	capacity l/h	weight kg	dimensions L x W x H mm
MP 2,000 - 5	1.5	420	300	2,000/950/1,600
MP 4,000 - 2	1.5	1,500	580	2,040/1,040/1,750
P 13 EMRT	8.0	3,000	700	2,150/1,750/1,500

Calculation of Elongation

The stressing records are part of the structural design and serve as a basis for the stressing operation. Besides the prestressing data, they contain the sequence of stressing and directives for procedures directly connected with

the stressing operation, such as lowering of the formwork and releasing of bearings.

Calculation of Strand Tendon Elongation

The total elongation DL_{tot} which the tendon has to achieve during stressing should be calculated as:

$$DL_{tot} = DL_p + DL_c + DL_{sl} + DL_e$$

DL_p = elongation of the strand tendon [mm]

$$DL_p = \frac{1}{A_p \cdot E_p} \cdot \int_0^{L_p} P_{x,0} \cdot dx$$

L_p = length of tendon [m]

- $P_{x,0}$ = prestressing force in the tendon at any point at distance x [kN]
- $P_{x,0} = P_0 \cdot e^{-\mu(\sum \alpha_x + k \cdot L_p)}$
- P_0 = prestressing force at the stressing anchorage [kN]
- $\sum \alpha_x$ = Σ angle of planned deflections between the stressing anchorage and any point at distance x [rad]
- $\sum \alpha_x = \frac{P}{180} \sum_{i=1}^n S_i \sin^2 \alpha_{vi} + \alpha_{hi}^2$
- α_{vi}, α_{hi} = vertical and horizontal projections of the angle of i -th deflection [°]
- μ = friction coefficient [rad⁻¹] (see p.7)
- k = wobble coefficient [rad/m] (see p.7)
- P_e = prestressing force at the stressing anchorage after wedge draw-in [kN]
- A_p = cross sectional area of prestressing strands

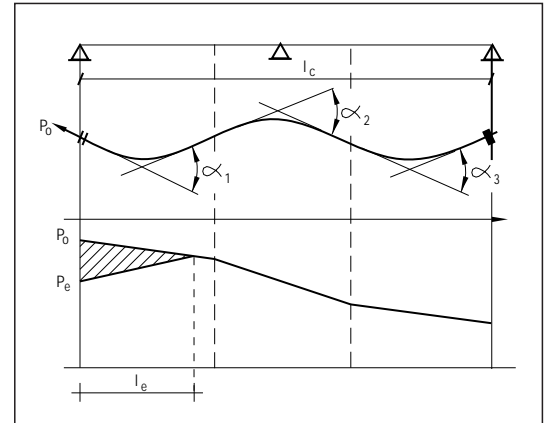

DL_c = elastic deformation of the concrete (shortening must be treated as a positive value) [mm]

$$DL_c = \frac{S_{cm}}{E_c} \cdot L_c$$

- S_{cm} = average stress in the concrete cross section at the center of gravity of all tendons due to prestressing force [MN/m²]
- L_c = length of the concrete member [m]

DL_{sl} = sum of anchor plate impressions and wedge draw-in according to the anchorage/coupling type applied [mm]

slip DL_{sl} [mm]	stressing anchorage	dead end anchorage	bond head anchorage	coupler R	coupler D	coupler M
accessible	1	6	-	-	-	4
not accessible	-	4	-	4	8	-

Values are based on prestressing force acc. to European Technical Approval

DL_e = elongation of the prestressing steel in the jack and seating device (if applicable) [mm]

Calculation of Elongation

Calculation of Prestressing Force P_e [kN] at Stressing Anchorage and Influence Length L_e [m]

due to wedge draw-in DL_n [mm] at stressing anchorage during lock-off of tensioning jack

$$L_e = \frac{DL_n \cdot E_p \cdot A_p}{P_0 \cdot \mu \cdot g_1}$$

g_1 = average angle of deflection along the influence length L_e of tendon behind the stressing anchorage [rad/m]

$$P_e = P_0 \cdot (1 - 2 \cdot L_e \cdot \mu \cdot g_1)$$

draw-in slip DL_n [mm]	tendon type	jack type	
		standard case	special case
at the stressing anchorage	6803 - 6837	4*	8**
at the coupler M	6802 - 6812	8	-

values are based on prestressing force acc. to European Technical Approval
 *) with wedge seating **) without wedge seating

modulus of elasticity [N/mm²]

concrete class	C 20/25	C 30/37	C 40/50	C 50/60
E_{cm}	29,000	32,000	35,000	37,000

strand $E_p = 195,000$ [N/mm²]

Addresses

DSI Holding GmbH

Dywidagstrasse 1
85609 Aschheim
Germany
Phone +49-89-30 90 50-200
Fax +49-89-30 90 50-252
E-mail: info@dywidag-systems.com
www.dywidag-systems.com

RHQ Americas

DYWIDAG-SYSTEMS
INTERNATIONAL USA INC.
320 Marmon Drive
Bolingbrook, IL 60440
USA
Phone +1-630-739 11 00
Fax +1-630-972 96 04
E-mail: dsiamerica@dsiamerica.com
www.dsiamerica.com

RHQ Europe

DYWIDAG-SYSTEMS
INTERNATIONAL GMBH
Siemensstrasse 8
85716 Unterschleissheim
Germany
Phone +49-89-30 90 50-100
Fax +49-89-30 90 50-120
E-mail: dsihv@dywidag-systems.com
www.dywidag-systems.com

RHQ Underground

DYWIDAG-SYSTEMS
INTERNATIONAL PTY. LTD.
P.O. Box 370
Charlestown NSW 2290, Australia
25 Pacific Highway
Bennetts Green NSW 2290
Phone +61-2-49 48 90 99
Fax +61-2-49 48 40 87
E-mail: dsi@dywidag.com.au
www.dsिमiningproducts.com

Europe

Austria
DYWIDAG-SYSTEMS
INTERNATIONAL GMBH
Christophorusstrasse 12
5061 Elsbethen/Salzburg, Austria
Phone +43-662-62 57 97
Fax +43-662-62 86 72
E-mail: dsi-a@dywidag.co.at
www.dywidag-systems.at

Belgium and Luxembourg
DYWIDAG-SYSTEMS
INTERNATIONAL N.V.
Industrieweg 25
3190 Boortmeerbeek, Belgium
Phone +32-16-60 77 60
Fax +32-16-60 77 66
E-mail: info@dywidag.be

Croatia, Bosnia and Herzegovina
PRESS-KON
Obala Hrvatskog
narodnog preporoda 6
21000 Split, Croatia
Phone +385-21-34 27 66
Fax +385-21-3425 95

Czech Republic
SM 7, A.S.
Modřanská 43
14700 Praha 4, Czech Republic
Phone +420-2-44 46 15 40
Fax +420-2-44 46 07 52
E-mail: chvala@sm7-dsi.cz

Denmark
AAGE CHRISTENSEN A/S
Skelmosevej 10
2500 Valby, Denmark
Phone +45-36-44 24 44
Fax +45-36-44 20 24
E-mail: dsi@aagechristensen.dk

Estonia
SAGA Grupp
Peterburi tee 90
11415 Tallinn, Estonia
Phone +372 601 29 34
Fax +372 601 29 35
E-mail: erki.saar@saga.ee

Finland

TENSICON OY
Rattitie 17
007700 Helsinki 77, Finland
Phone +358-9-35 05 99 0
Fax +358-9-35 05 99 10

France

DYWIDAG-SYSTEMS
INTERNATIONAL GMBH
Succursale France
8, rue du Grand Pré
95640 Marines, France
Phone +33-1-30 39 42 42
Fax +33-1-30 39 62 72
E-mail: dsi.france@dywidag.fr
www.dywidag.fr

Agence de Lyon
14, rue de la Prairie
69100 Villeurbanne, France
Phone +33-4-78 79 27 82
Fax +33-4-78 79 01 56
E-mail: dsi.france@dywidag.fr

Agence de Marseille
55, rue Louis Armand - BP 266
13797 Aix-en-Provence Cedex 3,
France
Phone +33-4-42 24 56 46
Fax +33-4-42 90 00 58
E-mail: dsi.france@dywidag.fr

Germany
SUSPA-DSI GmbH
Max-Planck-Ring 1
40764 Langenfeld, Germany
Phone +49-2173-79 02 0
Fax +49-2173-79 02 20
E-mail: info@suspa-dsi.de
www.suspa-dsi.de

SUSPA-DSI GmbH
Germanenstrasse 8
86343 Koenigsbrunn, Germany
Phone +49-8231-96 07 0
Fax +49-8231-96 07 40
E-mail: info@suspa-dsi.de

SUSPA-DSI GmbH
Schuetzenstrasse 20
14641 Nauen, Germany
Phone +49-3321-44 18 32
Fax +49-3321-44 18 18
E-mail: info@suspa-dsi.de

DYWIDAG-SYSTEMS
INTERNATIONAL GMBH
Business Unit Form Ties Systems
Schallbruch 53-55
42781 Haan, Germany
Phone +49-2129-93 22 0
Fax +49-2129-93 22 10
E-mail: dsahaan@dywidag-systems.com

United Kingdom

DYWIDAG-SYSTEMS
INTERNATIONAL LTD.
Northfield Road
Southam, Warwickshire
CV47 0FG, England
Phone +44-1926-81 39 80
Fax +44-1926-81 38 17
E-mail: sales@dywidag.co.uk
www.dywidag.co.uk

Greece

For Geotechnical Systems
HELLENPLAN
18, Filolaou Street
Athens 11633, Greece
Phone +30-210-752 07 53
Fax +30-210-751 210 68
E-mail: vtsio@tee.gr

For Post-Tensioning Systems
Kostantinos Zervas
34th Sintagmatos Pezikon 5
Pireas TK 18532 Athens
Greece
Phone +30-210-417 62 76
Fax +30-210-412 21 23
E-mail: kzervas@tee.gr

Italy

DYWIT S-P-A
Via Albricci, 5
20122 Milano, Italy
Phone +39-02-72 00 06 77
Fax +39-02-86 93 93 5
E-mail: dywit@tin.it

Addresses

Netherlands

DYWIDAG-SYSTEMS
INTERNATIONAL B.V.
Veilingweg 2
5301 KM Zaltbommel
Netherlands
Phone +31-418-57 89 22
Fax +31-418-51 30 12
E-mail: email@dsi-nl.nl
www.dsi-nl.nl

Norway

DYWIDAG-SYSTEMS
INTERNATIONAL A/S
P.O. Box 113
1483 Skytta, Norway
Phone +47-67-06 15 60
Fax +47-67-06 15 59
E-mail: manager@dsi-dywidag.no

Portugal

DYWIDAG-SYSTEMS
INTERNATIONAL GMBH (Sucursal)
Alameda dos Oceanos, lote 3.15.01 D
Escritório 7
1990 - 197 Lisboa, Portugal
Phone +351-21-892 28 90
Fax +351-21-892 28 99
E-mail: dsi.lisboa@dywidag.pt

Russia

Promstroikontarkt
h. 10, 3-rd Setunsky Proezd, Moscow,
Russia, 119136
Phone +7 095 247-90-91
Fax +7 095 789-34-12
E-mail: psk@psk-holding.ru
www.psk-holding.ru

Sweden

SpännProjekt
Tallhammarsvägen 11
18633 Vallentuna, Sweden
Phone +46-8-51 17 51 00
Fax +46-8-51 17 17 00
E-mail: spannprojekt
@beta.telenordia.se

Turkey

DIVIGER Yapı Teknoloji A.S.
Yıldızposta Cd. Ayyıldız Sitesi 30/15
34353 İstanbul-Gayrettepe, Turkey
Phone +90-212-234 56 12
Fax +90-212-347 39 49
E-mail: diviger@diviger.com

Switzerland

SpannStahl AG
Industriegebiet
Waesserstrasse 29
8340 Hinwil/ZH, Switzerland
Phone +41-1-938 97 97
Fax +41-1-938 97 90
E-mail: info@spannstahl.ch
www.spannstahl.ch

Spain

DYWIDAG SISTEMAS
CONSTRUCTIVOS, S.A.
Avenida de la Industria, 4
Pol. Ind. La Cantuena
28947 Fuenlabrada (MADRID), Spain
Phone +34-91-642 20 72
Fax +34-91-642 27 10
E-mail: dywidag
@dywidag-sistemas.com
www.dywidag-sistemas.com

Far and Middle East

Iran

PADSI CO.
31, Varshow St.
Nejatollahi (Villa) Ave.
Tehran - 15986 Iran
Phone +98-21-890 17 99
Fax +98-21-890 53 78

Lebanon

SOPREL Liban SAL
Liban Cable Street
Halate, Lebanon
Phone +961 9 44 88 60
Fax +961 9 44 71 71
E-mail: contact@soprel-liban.com

Saudi Arabia

DYWIDAG
SAUDI ARABIA CO., LTD
P.O. Box 1261
Jubail 31951,
Kingdom of Saudi Arabia
Phone +966-3-341-63 06 / 341 63 07
Fax +966-3-341-63 02
E-mail: dsa@dywidag.com.sa

Turkey

DIVIGER Yapı Teknoloji A.S.
Yıldızposta Cd. Ayyıldız Sitesi 30/15
34353 İstanbul-Gayrettepe, Turkey
Phone +90-212-234 56 12
Fax +90-212-347 39 49
E-mail: diviger@diviger.com

United Arab Emirates, Qatar, Oman

MBM
23rd Street (Villa No. 28/3)
Abu Dhabi - U.A.E.
Phone +971-2-448 32 32
Fax +971-2-448 32 36
E-mail: mbm@mbmauh.ae

North and Central America

USA

DYWIDAG-SYSTEMS
INTERNATIONAL USA INC.

Headquarter

320 Marmon Drive
Bolingbrook, IL 60440, USA
Phone +1-630-739 11 00
Fax +1-630-972 96 04
E-mail: dsiamerica@dsiamerica.com
www.dsiamerica.com

Business Unit

Post-Tensioning & Reinforcement

320 Marmon Drive
Bolingbrook, IL 60440, USA
Phone +1-630-739 11 00
Fax +1-630-972 96 04
E-mail: dsiamerica@dsiamerica.com

525 Wanaque Avenue

Pompton Lakes, NJ 07442, USA
Phone +1-973-831-6560
Fax +1-973-831-6503
E-mail: dsiamerica@dsiamerica.com

1801 N. Peyco Drive

Arlington, TX 76001-6704, USA
Phone +1-817-465 33 33
Fax +1-817-465 36 96
E-mail: dsiamerica@dsiamerica.com

4732 Stone Drive, Suite B

Tucker, GA 30084, USA
Phone +1-770-491 37 90
Fax +1-770-938 12 19
E-mail: dsiamerica@dsiamerica.com

2154 South Street

Long Beach, CA 90805, USA
Phone +1-562-531 61 61
Fax +1-562-531 26 67
E-mail: dsiamerica@dsiamerica.com

Business Unit

Geotechnical Systems

1263 Newark Road
Toughkenamon, PA 19374, USA
Phone +1-610-268-2221
Fax +1-610-268-3053
E-mail: support@dsiamerica.com

1305 S. Central Ave

Unit H
Kent, WA 98032, USA
Phone +1-253-859-9995
Fax +1-253-859-9119
E-mail: support@dsiamerica.com

320 Marmon Drive

Bolingbrook, IL 60440, USA
Phone +1-630-739 11 00
Fax +1-630-972 96 04
E-mail: support@dsiamerica.com

525 Wanaque Avenue

Pompton Lakes, NJ 07442, USA
Phone +1-973-831-6560
Fax +1-973-831-6503
E-mail: dsiamerica@dsiamerica.com

1801 N. Peyco Drive

Arlington, TX 76001-6704, USA
Phone +1-817-465 33 33
Fax +1-817-465 36 96
E-mail: support@dsiamerica.com

4732 Stone Drive, Suite B

Tucker, GA 30084, USA
Phone +1-770-491 37 90
Fax +1-770-938 12 19
E-mail: support@dsiamerica.com

2154 South Street

Long Beach, CA 90805, USA
Phone +1-562-531 61 61
Fax +1-562-531 3266
E-mail: support@dsiamerica.com

Business Unit

Monostrand

2154 South Street
Long Beach, CA 90805, USA
Phone +1-562-531 61 61
Fax +1-562-531 2667
E-mail: dsiamerica@dsiamerica.com

320 Marmon Drive

Bolingbrook, IL 60440, USA
Phone +1-630-739 11 00
Fax +1-630-972 96 04
E-mail: dsiamerica@dsiamerica.com

525 Wanaque Avenue

Pompton Lakes, NJ 07442, USA
Phone +1-973-831-6560
Fax +1-973-831-6503
E-mail: dsiamerica@dsiamerica.com

1801 N. Peyco Drive

Arlington, TX 76001-6704, USA
Phone +1-817-465 33 33
Fax +1-817-465 36 96
E-mail: dsiamerica@dsiamerica.com

10060 N.W. 53rd Street

Sunrise, Florida 33351
Phone +1-954-318-1105
Fax +1-954-318-1107
E-mail: dsiamerica@dsiamerica.com

Addresses

Business Unit

Form Tie Systems
2154 South Street
Long Beach, CA 90805, USA
Phone +1-562-531 6161
Fax +1-562-531 2667
E-mail: dsiamerica@dsiamerica.com

Canada
DYWIDAG-SYSTEMS
INTERNATIONAL
CANADA LTD.

Eastern Division
37 Cardico Drive
Gormley, ON L0H1G0
Canada
Phone +1-905-888-8988
Fax +1-905-888-8987
E-mail: ecd@dsiamerica.com
www.dsicanada.ca

Quebec Office
St. Bruno
Quebec, ON, J3V 6E2
Canada
Phone +1-450-653-0935
Fax +1-450-653-0977
E-mail: ecd@dsiamerica.com
www.dsicanada.ca

Western Division
Suite 103
19433 96th Av.
Surrey, BC V4N4C4
Canada
Phone +1-604-888-8818
Fax +1-604-888-5008
E-mail: wcd@dsiamerica.com
www.dsicanada.ca

Calgary Office
#204, 2816 - 21 Street N.E.
Calgary, Alberta T2E 6Z2
Canada
Phone +1-403-291-4414
Fax +1-403-250-5221
E-mail: wcd@dsiamerica.com
www.dsicanada.ca

Central America

Headquarters
525 Wanaque Avenue
Pompton Lakes, NJ 07442, USA
Phone +1-973-831-6560
Fax +1-973-831-6503
E-mail: dsiamerica@dsiamerica.com

Costa Rica
SUPERBA S.A.
Pozuelo 100M Norte y 25 Oeste
La Uruca, San José, Costa Rica
Phone +50-6-255 10 44
Fax +50-6-255 11 10
E-mail: superba@sol.racsas.co.cr

Guatemala
Preforzados y Construcciones S.A.
5 Av.6-39
zona 14 Las Plazas
Guatemala 01014
Phone +50-2-631-4882/4
Fax +50-2-368-3531
E-Mail: precon@terra.com.gt

Honduras
Lazarus & Lazarus
200 Mts. Al Este de Posta de Peaie
Boulevard del Sur
Chamalecon Cortes
Phone +50-4565-8882
Fax +50-4565-8624
E-Mail: elazarus@lazarus.hn

Mexico
DSI Mexico, S.A. DE C.V.
Calle Tecuitapan #6
Col. Las Palmas CP 62050
Cuernavaca, Morelos, Mexico
Industria del Vestido # 2153
Zapopan, Jalisco - Mexico 45132
Phone +52-7773-12 64 96
Fax +52-7773-14 14 79
E-mail: dsimexico@infosel.net.mx

South America

Argentina-Uruguay-Paraguay
Compañía Sudamericana de
Postensado
CSP-DSI Argentina
Av. Leandro N. Alem 661 7° Piso Of.
17
1001 Buenos Aires
Argentina
Phone +54-11-43 12-44 34 / 35
Fax +54-11-43 12-11 43
E-mail: info@csp-dsi.com

Brazil
PROTENDIDOS DYWIDAG LTDA.
Rua Isia, 150-cj41
04542-060 - São Paulo - SP
Brazil
Phone +55-11-2131-3700
Fax +55-11-2131-3700
E-mail: info@dywidag.com.br
www.dywidag.com.br

Chile
Compañía Sudamericana de
Postensado
CSP-DSI Chile
Av. Apoquindo 3076 Piso 6
Santiago de Chile, Chile
Phone +56-2-952 0679
Fax +56-2-952 0681
E-mail: info@csp-dsi.cl

Sr.Miguel Mandry
E.Marquina 3937 of.608
Vitacura
Santiago de Chile, Chile
Phone +56-2-2074585
Fax +56-45-718-336
E-mail: migmandry@terra.cl

Colombia
TENSAR LTDA.
Transversal 70-B No. 4-36
Santa Fé de Bogotá, Colombia
Phone +57-1-262 66 85
Fax +57-1-261 28 82
E-mail: tensar1@latino.net.co

Peru

SAMAYCA INGENIEROS S.A.C.
Av. A. Benavides 245 Of.604-605
Lima, Perú
Phone +51-1-446 33 56
Fax +51-1-445 66 28
E-mail: samayca@terra.com.pe

Venezuela
POSTENSADO V.N. INDUSTRIAL DE
VENEZUELA S.A. (PIV)
Quinta IMOLA
6ta. transv., entre 2da y 3ra AV.
Urb. Los Palos Grandes
Caracas, Venezuela
Phone +58-212-261-8516
Fax +58-212-261-2854
E-mail: postensado@cantv.net

Africa

Egypt
MISR DYWIDAG
20 Haroun Street
Dokki-Giza
Cairo, Egypt
Phone +20-2-748 28 27
Fax +20-2-748 62 53
E-mail: mail@misrdywidag.com

Addresses

Asia

China
DYWIDAG-SYSTEMS
INTERNATIONAL
FAR EAST LTD.
Room 2306
CC Wu Building
302-308 Hennessy Road
Wanchai, Hong Kong
Phone +852-2833-91 70
Fax +852-2834-55 21
E-mail: dsihk@dsife.com.hk

Indonesia
PT DELTA SYSTECH INDONESIA
Wisma Ritra 2nd Floor
Jl. Wr. Buncit Raya No.6
Jakarta - 12740
Indonesia
Phone +62-21-797 02 89
Fax +62-21-797 08 25
E-mail: yunaldi@dsi-indonesia.co.id

Japan
SUMITOMO ELECTRIC
INDUSTRIES LTD.
Special Steel Wire Division
3-12 Motoakasaka
1-chome Minato-ku
Tokyo, 107 Japan
Phone +81-3-34 23 51 31
Fax +81-3-34 23 50 01
E-mail: katsuda-hiroka@sei.co.jp

Korea
DYWIDAG-SYSTEMS
KOREA CO.LTD.
5th Floor, Spring Morning B/D
249-2 Yangjae-dong Seocho-ku
Seoul 137-130 Korea
Phone +82-2-34 72 01 41
Fax +82-2-34 72 01 45
E-mail: dywidag@chollian.net
www.dsikorea.co.kr

Singapore
UTRACO STRUCTURAL
SYSTEMS PTE LTD
7E Pioneer Sector 1
Singapore 628446
Phone +65-64153078
Fax +65-68631928
E-mail: utracoss@utracoss.com
www.utracoss.com

Taiwan
DYWITECH Co., Ltd.
13th Fl.-3, No. 163, Sec. 1, Keelung
Road
Taipei 110
Taiwan, R.O.C.
Phone +886-2-27 48 10 76
Fax +886-2-27 47 05 76
E-mail: dsitaiwan@dywidag-systems.com.tw

Thailand
D-Tech Postten Co., Ltd.
1350/136-137
10/F, Thairon Tower Building
Pattanakarn Road
Suan Luang District
Suan Luang
Bangkok 10250
Thailand
Phone +66-02-719-51 67
Fax +66-02-719-53 91
E-mail: kritpsu@yahoo.com

RHQ Mining & Tunneling

Australia
DYWIDAG-SYSTEMS
INTERNATIONAL PTY. LTD.

Eastern Australia
25 Pacific Highway
Bennetts Green NSW 2290
Australia
Phone +61-2-49 48 90 99
Fax +61-2-49 48 43 15
E-mail: dsi@dywidag.com.au
www.dsiminingproducts.com

Western Australia
170 Railway Parade
Bassendean WA 6054
Australia
Phone +61-8-94 49 83 33
Fax +61-8-94 49 83 25
E-mail: dsi@dywidag.com.au

Mount Isa
199 Camooweal Street
Mt Isa QLD 4825
Australia
Phone +61-7-47 43 42 44
Fax +61-7-47 43 27 11
E-mail: dsi@dywidag.com.au

Emerald
3 McKenzie Street
Emerald QLD 4720
Australia
Phone +61-7-49 82 06 02
Fax +61-7-49 87 42 58
E-mail: dsi@dywidag.com.au

Kalgoorlie
Lot 15 Cunningham Road
Kalgoorlie WA 6430
Australia
Phone +61-8-90 91 19 93
Fax +61-8-90 91 41 72
E-mail: dsi@dywidag.com.au

South Africa
DYWIDAG-SYSTEMS
INTERNATIONAL PTY. LTD
P.O. Box 60 59
Homestead 1412
30 North Reef Road
Elandsfontein
Johannesburg
Gauteng South Africa
Phone +27-11 878 68 00
Fax +27-11 878 68 11
E-mail: dsi@dywidag.co.za
www.dywidag-sa.com

DSI-Mandirk
P.O. Box 60 59
Homestead 1412
30 North Reef Road
Elandsfontein
Johannesburg
Gauteng South Africa
Phone +27-11 878 68 00
Fax +27-11 878 68 11
E-mail: dsi@dywidag.co.za

America
DSI-Thiessen Mining Division
1638 Alberta Avenue
Saskatoon, SK S7K 1R6
Phone +1-306-244-6244
Fax +1-306-931-3481
E-mail: dsiamerica@dsiamerica.com

DSI-Thiessen Mining Division
5492 - 275th Street
Langley, BC V4W 3X7
Phone +1-604-857-1500
Fax +1-604-857-1580
E-mail: dsiamerica@dsiamerica.com

DSI Ground Support
560 Notre Dame Avenue
Sudbury, ON P3C 5L2
Phone +1-705-674-5844
Fax +1-705-674-5867
E-mail: dsiamerica@dsiamerica.com

DSI Ground Control
1150 Kelly Lake Road
Sudbury, ON P3E 5P4, Canada
Phone +1-705-673-3020
Fax +1-705-673-5946
E-mail: dsiamerica@dsiamerica.com

DSI-Stewart
154, 14th Ave.
Rouyn - Noranda, PQ J9X 2J5
Canada
Phone +1-819-762-0901
Fax +1-819-797-1367
E-mail: dsiamerica@dsiamerica.com

DSI Ground Support
3900 West 700 South
Salt Lake City, UT 84104, USA
Phone +1-801-973-7169
Fax +1-801-973-7172
E-mail: dsiamerica@dsiamerica.com
www.dsigroundsupport.com

DSI Ground Support
214 Railroad Street
Winber, PA 15963
Phone +1-814-467-7030
Fax +1-814-467-7031
E-mail: dsiamerica@dsiamerica.com

DSI Ground Support
4200 Highway 22 East
Suite 7 Bay #8
Blairsville, Pa. 15717
Phone +1-724-676-2000
Fax +1-724-676-2100
E-mail: dsiamerica@dsiamerica.com

Mexico
DSI Anclas Mineras S.A. de C.V.
Industria del Vestido # 2153
Zapopan, Jalisco - Mexico 45132
Phone +52-33-3656-5588
Fax +52-33-3656-5598
E-mail: dsiamerica@dsiamerica.com
www.dsigroundsupport.com

DSI Holding GmbH

Dywidagstrasse 1
85609 Aschheim
Germany
Phone +49-89-30 90 50-200
Fax +49-89-30 90 50-252
E-mail: info@dywidag-systems.com
www.dywidag-systems.com

RHQ Americas

DYWIDAG-SYSTEMS
INTERNATIONAL USA INC.
320 Marmon Drive
Bolingbrook, IL 60440
USA
Phone +1-630-739 11 00
Fax +1-630-972 96 04
E-mail: dsiamerica@dsiamerica.com
www.dsiamerica.com

RHQ Europe

DYWIDAG-SYSTEMS
INTERNATIONAL GMBH
Siemensstrasse 8
85716 Unterschleissheim
Germany
Phone +49-89-30 90 50-100
Fax +49-89-30 90 50-120
E-mail: dsihv@dywidag-systems.com
www.dywidag-systems.com

RHQ Underground

DYWIDAG-SYSTEMS
INTERNATIONAL PTY. LTD.
P.O. Box 370
Charlestown NSW 2290, Australia
25 Pacific Highway
Bennetts Green NSW 2290
Phone +61-2-49 48 90 99
Fax +61-2-49 48 40 87
E-mail: dsi@dywidag.com.au
www.dsiminingproducts.com

AUSTRIA
ARGENTINA
AUSTRALIA
BELGIUM
BOSNIA AND HERZEGOVINA
BRAZIL
CANADA
CHILE
COLOMBIA
COSTA RICA
CROATIA
CZECH REPUBLIC
DENMARK
EGYPT
ESTONIA
FINLAND
FRANCE
GERMANY
GREAT BRITAIN
GREECE
GUATEMALA
HONDURAS
HONG KONG
INDONESIA
IRAN
ITALY
JAPAN
KOREA
LEBANON
LUXEMBOURG
MALAYSIA
MEXICO
NETHERLANDS
NORWAY
OMAN
PANAMA
PARAGUAY
PERU
POLAND
PORTUGAL
QATAR
SAUDI ARABIA
SINGAPORE
SOUTH AFRICA
SPAIN
SWEDEN
SWITZERLAND
TAIWAN
THAILAND
TURKEY
UNITED ARAB EMIRATES
URUGUAY
USA
VENEZUELA

Details, dimensions and system designs are subject to change without notice.